

# Operator's Manual

Gauges for coating thickness measurement

**DELTA SCOPE® DMP30**

**ISO SCOPE® DMP30**

**DUAL SCOPE® DMP40**



Gauges for coating thickness measurement

DELTA SCOPE® DMP30 (1007331)

ISO SCOPE® DMP30 (1007332)

DUAL SCOPE® DMP40 (1007333)

Document Number: 1008996

Edition: 03-2023 (from Firmware version 1.0.0)

#### Manufacturer

---

Helmut Fischer GmbH	Phone: +49 (0) 70 31 3 03 - 0
Institut für Elektronik und Messtechnik	Fax: +49 (0) 70 31 3 03 - 710
Industriestraße 21	www.helmut-fischer.com
D-71069 Sindelfingen	mail@helmut-fischer.com

On our home page [www.helmut-fischer.com](http://www.helmut-fischer.com) you will find the addresses of our sole agencies and subsidiary companies around the globe.

Quality Assurance System of the Helmut Fischer GmbH Institut für Elektronik und Messtechnik

---

DIN EN ISO/IEC 17025 Calibration lab accredited for certified mass per unit area standards

DIN EN ISO 9001:2015 Management system certified by Swiss Association for Quality and Management Systems (SQS)

© 2023 by Helmut Fischer GmbH Institut für Elektronik und Messtechnik, Germany.

This document is protected by copyright. All rights reserved. This document may not be reproduced by any means (print, photocopy, microfilm or any other method) in full or in part, or processed, multiplied or distributed to third parties by electronic means without the written consent of Helmut Fischer GmbH Institut für Elektronik und Messtechnik.

Subject to correction and technical changes.

DELTA SCOPE®, ISO SCOPE®, DUAL SCOPE® are registered trade marks of the Helmut Fischer GmbH Institut für Elektronik und Messtechnik in Germany and other countries.

Microsoft™ and Excel™ are registered trade marks of the Microsoft Corporation, USA.

Bluetooth® is a registered trade mark of the Bluetooth SIG, USA.

Note: Designations not marked with ® or ™ may also be protected by law.

1	Safety . . . . .	1
1.1	Warnings and icons used . . . . .	1
1.2	Intended use . . . . .	2
1.3	Safety of the electrical equipment . . . . .	2
1.4	Maintenance and repairs . . . . .	4
1.5	Disposal . . . . .	4
2	Limitation of liability . . . . .	5
3	Description . . . . .	5
3.1	Scope of supply . . . . .	6
3.2	Gauge . . . . .	6
3.3	Overview of signals . . . . .	7
3.4	Softkey – icons/codes . . . . .	7
3.5	Measurement view . . . . .	9
3.6	Display icons/codes . . . . .	9
3.7	Menus – function overview . . . . .	12
3.8	Statistical characteristic variables . . . . .	15
3.9	Technical Data . . . . .	17
4	Guide . . . . .	28
5	Rechargeable battery . . . . .	29
5.1	Changing the battery . . . . .	29
5.2	Charging the battery . . . . .	31
6	Connecting/replacing probe . . . . .	33
6.1	Connecting the probe . . . . .	33
6.2	Replacing the probe – connecting a different probe . . . . .	35
7	Settings for measurement . . . . .	37
7.1	Creating a new batch . . . . .	37
7.2	Opening a batch . . . . .	38
7.3	Activating/deactivating specification limit monitoring . . . . .	38
7.4	Activating/deactivating automatic block formation . . . . .	39
7.5	Activating/deactivating offset function . . . . .	40
7.6	Selecting measuring mode . . . . .	41
7.7	Save measured readings on/off . . . . .	43
7.8	Air reference value – automatic/manual acquisition . . . . .	43
7.9	Assigning a different calibration to the opened batch . . . . .	44

8	Measure . . . . .	46
	8.1 Notes on measuring . . . . .	46
	8.2 Handling the probe . . . . .	47
	8.3 Before you start . . . . .	47
	8.4 Measuring in single reading measuring mode - procedure . . . . .	49
	8.5 Measuring in free-running measuring mode - procedure. . . . .	51
	8.6 Measuring in scan measuring mode - procedure. . . . .	52
	8.7 Measuring with manual recording of the air reference value . . . . .	53
9	Calibration . . . . .	54
	9.1 Overview of calibration methods . . . . .	55
	9.2 Please observe the following information on calibration/recalibration	56
	9.3 Calibration – when is it necessary? . . . . .	57
	9.4 Recalibration. . . . .	57
	9.5 Calling up information about the calibration . . . . .	63
	9.6 Activating/deactivating semi-automatic calibration routine. . . . .	64
	9.7 Calibration - reset . . . . .	65
	9.8 Creating new calibration. . . . .	66
	9.9 Calibration - assigning/changing names . . . . .	67
	9.10 Checking the precision of a calibration . . . . .	68
	9.11 Defining the test criteria for the calibration check . . . . .	71
	9.12 Lock calibration . . . . .	72
	9.13 Calibration – deactivating lock . . . . .	73
	9.14 Deleting a calibration . . . . .	74
	9.15 Deleting all calibrations . . . . .	74
10	Evaluation. . . . .	76
	10.1 Batch statistics. . . . .	76
	10.2 Block statistics . . . . .	77
	10.3 Individual measured readings. . . . .	77
11	Data transfer . . . . .	78
	11.1 Data transfer via USB . . . . .	79
	11.2 Data transfer via Bluetooth . . . . .	80
12	Batch settings . . . . .	82
	12.1 Calling up information about the open batch. . . . .	82
	12.2 Changing the unit of measurement for the batch . . . . .	83
	12.3 Selecting the Measurement view for the batch. . . . .	85
	12.4 Selecting characteristic variables for the statistical displays . . . . .	86
	12.5 Setting the decimal places for the display values. . . . .	87

13	Batch management . . . . .	88
13.1	Assigning/changing batch names . . . . .	88
13.2	Copying a batch . . . . .	88
13.3	Deleting a batch . . . . .	89
14	Gauge settings . . . . .	90
14.1	Setting the language . . . . .	90
14.2	Display settings . . . . .	90
14.3	Signal settings – visual and audible signals. . . . .	91
14.4	Energy saving . . . . .	92
14.5	Activating/deactivating the Bluetooth function . . . . .	92
14.6	Date & time . . . . .	93
14.7	Default settings for unit of measurement and decimal places . . . . .	94
14.8	Activating/deactivating lock code. . . . .	94
14.9	Reducing electromagnetic interference on the measurement. . . . .	95
15	Service. . . . .	96
15.1	Probe – count rate recording/display . . . . .	96
15.2	Gauge cleaning . . . . .	97
16	Gauge information . . . . .	98



# 1 Safety

- ▶ Refer to the safety information before starting-up this gauge in order to avoid damage to property or personal injury.
- ▶ Keep this manual in a safe place to be able to refer to any necessary descriptions at a later date.

## 1.1 Warnings and icons used

### ATTENTION

Indicates a danger that can lead to damage or destruction of the product.



### CAUTION

Indicates a low-risk danger that could result in minor or moderate injuries or damage to property if not avoided.



### WARNING

Indicates a medium-risk danger, which could result in death or serious injuries if not avoided.



### DANGER

Indicates a high-risk danger, which could instantly result in death or serious injuries if not avoided.

### NOTE

Indicates helpful information, tips and notes



Page reference

Indicates references to further descriptions

## 1.2 Intended use

The gauge is intended solely for the measurement of coating thicknesses.

The measurement system (gauge and probe) is designed for operation under the following environmental conditions:

- Indoor and outdoor operation
- Operation outside potentially explosive areas only!
- Ambient temperature during operation: 0 ... +40 °C (+32 °F ... +104 °F)
- Operation at altitudes up to 2000 m (6561.7 ft) above sea level

Only accessories approved or recommended by the manufacturer may be connected to the gauge.

Any further use is not in accordance with the intended use. The risk of damage resulting from this is borne solely by the user!

### **! ATTENTION – Destruction of the gauge due to condensation**

If the gauge is moved from a cold environment to a warm environment, condensation can form inside the gauge and damage its electronics. Such extreme temperature changes occur e.g. in winter between outside (0 °C (+32 °F)) and room temperature (+22 °C (+71.6 °F)).

- ▶ Allow the gauge some time to acclimatize to the ambient temperature before turning it on and starting a measurement.

## 1.3 Safety of the electrical equipment

EMC (Directive 2014/30/EU, electromagnetic compatibility)

The gauges of the DMP series comply with the regulations concerning electromagnetic compatibility. The gauges are designed for battery operation. Mains operation via travel charger or PC is possible, but not recommended. The guaranteed conformity applies exclusively to battery operation!

**! ATTENTION – Damage due to high temperature**

When exposed to sunshine, the areas behind glass windows (e.g. in a car) can easily reach temperatures in excess of +50 °C (+122 °F). This can cause damage to the gauge.

Do not keep or store the gauge and accessories behind glass panes, or near to heat sources such as radiators etc.!

**! ATTENTION – No data transfer due to damaged connection and interconnection cables**

Kinking or pinching of the connecting or interconnecting cable will result in line breakage. Excessive pulling force can cause the cable to tear out of its connection. In all these cases, data transfer (measurement signal) is no longer possible.

- ▶ Always connect an undamaged cable to the gauge. USB: max. length 3 m (118.1 ")
- ▶ Store the cable only in coiled condition, coiling radius  $\geq 20$  mm (0.79 ").
- ▶ Do not use the probe and connection cable as a carrying aid!

**! ATTENTION – Wrong line voltage when charging the battery**

An incorrect line voltage can lead to damage or destruction of the USB charger.

- ▶ Check the specifications for the line voltage before plugging the USB charger into the socket. The local line voltage must match the line voltage specified on the type plate of the USB charger.



**CAUTION – when handling the battery**

Improper handling of the battery can cause the battery to overheat, leak or burst.

- ▶ Use only batteries specified by the manufacturer to operate this gauge:  
Type RRC 1130 (3.8 V, 14.47 Wh, scope of supply)
- ▶ Prevent metal objects such as necklaces, rings, etc. from short-circuiting the contacts.

- ▶ Do not continue to use the battery if you notice any changes such as discoloration, deformation or damage to the outer casing.
- ▶ Replace the battery if it is not charged after the usual charging time. The usual charging time can be found in the technical data.
- ▶ Do not expose the battery to excessive heat, moisture or direct contact with water.
- ▶ Store the gauge without the battery when not in use for a long period of time.

## 1.4 Maintenance and repairs

Modifications, repairs, as well as maintenance and service work on the gauge and accessories may be carried out only by service personnel authorized by the manufacturer.

Exception: changing the batteries/rechargeable batteries

## 1.5 Disposal



Do not dispose of old electronic devices and electronic accessories with household refuse!

- ▶ Follow the instructions in your region on the proper disposal of old electronic devices and electronic accessories!
- ▶ Dispose of damaged or defective old devices and accessories in the designated collection containers!



Do not dispose of rechargeable batteries and batteries with household refuse!

- ▶ Follow the instructions in your region on the proper disposal of rechargeable batteries and batteries!
- ▶ Dispose of damaged or used rechargeable batteries and batteries in the designated collection containers!

## 2 Limitation of liability

The manufacturer accepts no liability and no responsibility for the precision, conclusions, and interpretation of the measurement results. Only continuous monitoring of the measurement devices by the user can guarantee the continued precision of measurements. The manufacturer accepts no liability or responsibility for consequential damage caused by the use of incorrect measured readings.

## 3 Description

The gauges of the DMP series measure coating thicknesses easily, quickly, and in a nondestructive manner. The gauge design with exchangeable probes allows a flexible use.

This Operator's Manual describes the following gauge models of the DMP series:

- DUALSCOPE® DMP40  
Coating thickness measurement on ferrous as well as on non-ferrous metal base materials (NC/FE, NF/FE, NC/NF)
- DELTASCOPE® DMP30  
Coating thickness measurement on non-ferrous base materials (NC/FE, NF/FE)
- ISOSCOPE® DMP30  
Coating thickness measurement on non-ferrous base materials (NC/FE)



Additional information can be found in the data sheet, from page 17

### 3.1 Scope of supply

- Gauge
- Li-ion battery
- USB cable type C to type A, 1 m (39.4 ")
- Safety information and quick guide
- Gauge case
- Fischer-Bluetooth stick

### 3.2 Gauge

- 1 Battery compartment lid, Bluetooth interface
- 2 Light strip for displaying the measured reading acquisition, specification limit violation, battery charge status
- 3 Display
- 4 Operation keys,  
⏻: on/off (press for approx. 2 s)  
☰: opens the menu when ⬆ is not shown in the bottom line of the display  
⬅ ⬆ ➡: navigation and selection keys

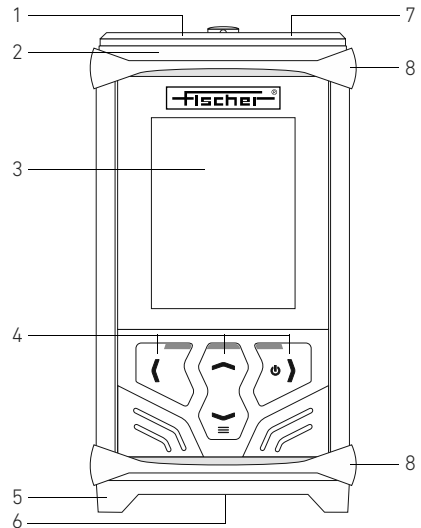
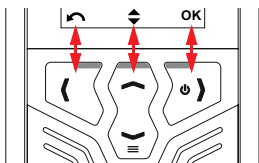



The bottom line of the display always shows the function for the keys directly underneath. The assignment depends on the open page view in the display (example).

- 5 Gauge foot
- 6 Probe connection and battery fast charging plug, USB type C
- 7 USB port, type C, under the sealing tab of the battery cover
- 8 Shock protection



Gauge dimensions and further properties, see data sheet, from page 17

### **Setting values faster**

- Measure once on the surface. You can use this value to set the desired value faster.
- Press and hold the arrow keys  or  longer.

## **3.3 Overview of signals**

If all signal functions in the gauge are activated, the gauge reports the following states:

Beeps

- Short beep = measured reading acquisition complete, second beep in addition if the specification limit is violated
- Long beep = block closure

Light signals

- Specification limit monitoring not active:  
Green = measured reading acquisition successful
- Specification limit monitoring active:  
Red = measured reading outside the specification limits, the measured reading itself is also displayed in red.  
Green = last measured reading is within the specification limits

Gauge vibration

- Measured reading acquisition completed, second vibration in addition in case of a specification limit violation or block closure



## **3.4 Softkey – icons/codes**

 Forward, skips the next step in the routine

 Back

- Returns to the previous menu page, displayed settings are applied
- Moves the cursor to the left, e.g. when the name is entered

 Opens the Measurement view

-  Calls up the calibration (calibration routine) from the Measurement view
-  Moves the cursor using the arrow keys
  - Moves the selection marking
  - Increases/decreases the numerical value displayed
-  Calls up the Delete function
- Opens another menu page
- Scrolls, displays the next page
- ✓ Run
  - Confirm the message/information
  - Starts the function (e.g. Delete function)
- ✗ Cancels the setting process and exits the function or returns to the previous page without saving any changes

**CLOSE** Sets a block closure when the block statistics are exited; available only when automatic formation is deactivated

**BLOCK** Calls up the block statistics for the current measured reading block

**OK** **Confirm**

- Confirms the selection/setting/information
- Moves the cursor to the right, e.g. when entering a name

**RUN** Starts continuous count rate acquisition

**STD** Calls up the page for entering the nominal value of the calibration foil/calibration standard used

**STOP** Ends the continuous count rate acquisition

**TH** Switches to coating thickness display in the count rate Measurement view (unit of measurement set as in the open batch)

**XN** Switches to count rate display in the count rate Measurement view



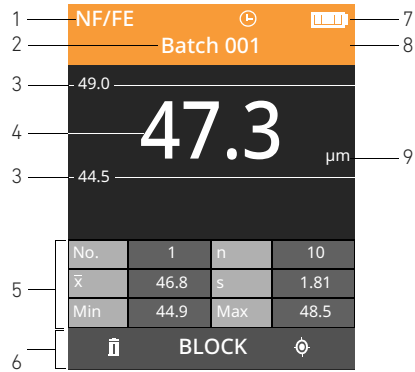

### 3.5 Measurement view

- 1 Currently measured coating/base material combination, NF/FE or NC/NF
- 2 Batch name
- 3 Specification limits
- 4 Reading currently being measured
- 5 Statistical values
- 6 Key assignment line (example: delete function, block statistics, calibration function)
- 7 Status displays; icons indicate active autom. gauge shutdown (clock), battery charge status or the active connection via USB or Bluetooth for example.
- 8 Information displays; icons indicate block closure, set measuring mode, offset, etc.
- 9 Unit of measurement



Example of the Measurement view showing statistics with set specification limits

### 3.6 Display icons/codes

-  *Statistics* menu, contains statistical evaluations and displays for the open batch.
-  *Batch Modify* menu, contains a list of alterable batch settings
-  *Batches* menu, contains a list of batches already created, the **New** function, for creating a new batch and the management function for batches already created: *Rename*, *Copy* and *Delete*
-  *Calibrations* menu, contains a list of calibrations already created, the *New* function for creating a new calibration and special functions for calibrations already created, e.g. *Rename*, *Shortened course* and *Delete*
-  *Gauge Settings* menu, contains a list of alterable gauge settings

 Indicates additional information

 Indicates warnings

NF/FE Displays the currently measured coating/base material combination: non-ferrous coating material on ferrous base material; display only with the DELTASCOPE® and DUALSCOPE® gauge models

NC/NF Displays the currently measured coating/base material combination: electrically non-conductive and non-ferrous coating material on electrically conductive non-ferrous metals; display only with the ISOSCOPE® and DUALSCOPE® gauge models

 Battery status indicator: fully charged

 Battery status indicator: replace battery soon

If the battery voltage is too low, the gauge switches off automatically, measured readings and settings are retained

 Energy-saving function, display dimming active

 A period of time for at least one of the energy-saving functions is set.

 USB connection active, gauge is connected to a PC via USB, for example



 White icon: Bluetooth function is activated in the gauge

 Blue icon: active Bluetooth connection, e.g. to a PC

 Red icon: the gauge cannot communicate with the inserted Bluetooth stick. Insert the Fischer-Bluetooth stick.

 Gray icon: the socket in the gauge for the Fischer-Bluetooth stick is empty, but the Bluetooth function is switched on.

 *Free Running* measuring mode active

 *Unlimited, Limited Number* or *Limited Number Block* scan mode is active, description of scan modes  41



*Counted Average* scan mode active

Measured reading acquisition until the probe is lifted off, storage of the arithmetic mean over the acquired measured readings



Indicates a block closure, appears with the last measured reading of the block



Offset function is active



The automatic storing of measured readings is deactivated



On/Off switch, – parameter/function is activated



On/Off switch, – parameter/function is deactivated



Parameter selection – parameter/function is activated



Parameter selection – parameter/function is deactivated

**No.** Number of the current block

**n** Number of measured readings

- Number of measured readings in the current/selected block
- Number of all measured readings in the current batch

$\bar{x}$  Arithmetic mean of the current block with  $n$  measured readings

**s** Standard deviation for the arithmetic mean  $\bar{x}$ ; a measure for the variation of individual measured readings (of a batch or block) around their common mean value.

**Min** Lowest measured reading within a block

**Max** Highest measured reading within a block

**R** The range equals the difference between the highest and lowest measured reading in a block or batch

**V[%]** Coefficient of variation, percentage variation of a series of measurements, standard deviation in terms of the mean value  $\bar{x}$ , a sudden change in the coefficient of variation indicates a change in process conditions

**n<USL** Number of measured readings per block or batch below the lower specification limit

**n>OGW** Number of measured readings per block or batch above the upper specification limit



Characteristic variables occurring during the control measurement for checking a selected calibration: a description of the characteristic variables can be found on page 69

## 3.7 Menus – function overview

### Menu *Statistics*

View of the statistics for the open batch

### *Batch Modify* menu

Settings and entries for the open batch

- *Batch Modify > MEASURE*  
Opens the Measurement view, starts the measurement with the probe positioned on the specimen surface
- *Batch Modify > Limits*  
Activates limit monitoring and sets the specification limits
- *Batch Modify > Batch Info*  
Information on the measurement and batch settings
- *Batch Modify > Views Settings*
  - Measurement view: selects the display
  - Batch statistical display: selects the statistical characteristic variables to be displayed
  - Block statistical display: selects the statistical characteristic variables to be displayed

- *Batch Modify > Meas. unit*  
Sets the unit of measurement
- *Batch Modify > Block Size*  
Activates automatic block formation and set the block size
- *Batch Modify > Offset*  
Sets the offset value
- *Batch Modify > More Settings > Measure Mode*  
Sets a measuring mode (single reading, free-running, , scan)
- *Batch Modify > More Settings > Values rounding*  
Sets the number of decimal places for the values displayed
- *Batch Modify > More Settings > Save Readings*  
Saves measured readings (yes/no)
- *Batch Modify > More Settings > Air Reference*  
Sets the acquisition method for the air reference value
- *Batch Modify > More Settings > Calibration Assign*  
Assigns a different calibration

## Menu *Batches*

- *Batches > New*, starts a routine for creating a new batch in the gauge.
- *Batches > List* containing the batches stored in the gauge;  
After a batch has been selected, it can be opened, renamed, copied, or deleted.

## Menu *Calibrations*

- *Calibrations > New*, starts a routine for creating a new calibration in the connected probe.
- *Calibrations > List* containing the calibrations stored in the connected probe;  
After a calibration has been selected, the following functions are available:
  - *CALIBRATE*  
Starts the calibration routine for the selected calibration
  - *Rename*  
Renames the selected calibration
  - *Def. Cal. Check*  
Defines test settings for checking the selected calibration

- *Check Calibration*  
Starts the checking procedure for the selected calibration
- *Lock Calibration*  
Locks the selected calibration, possible only with a pre-defined lock code
- *Shortened course*  
Activates a semi-automatic calibration routine
- *Reset*  
Deletes all coating thickness correction values from the selected calibration
- *Delete*  
Deletes the selected calibration from the probe memory
- *Info*  
Displays information about the selected calibration

## Gauge Settings menu

- *Gauge Settings > Language*  
Selects the display language
- *Gauge Settings > Display Settings*  
Activates/deactivates display flip function and display brightness
- *Gauge Settings > Signal Settings*
  - Audible signal on/off
  - Activates/deactivates the visual signals and sets the luminosity
  - Vibration on/off
- *Gauge Settings > Data Transfer*  
Data transfer via Bluetooth on/off;  
NOTE: A data transfer via USB and Bluetooth is possible only for evaluation purposes using Tactile Suite archiving software.
- *Gauge Settings > Energy Savings*  
Activates automatic gauge shutdown and display dimming after a preset period of time
- *Gauge Settings > Date & Time*  
Sets the date and time, and also the date and time format
- *Gauge Settings > More Settings*
  - *Preset Unit*  
Unit of measurement, default for creating the batch

- *Preset rounding*  
Number of decimal places for the values displayed, default for creating the batch
- *Define Lock Code/Delete Lock Code*  
Activates/deactivates the lock code for locking the calibration
- *Gauge Settings > Probe - Menu*
  - *Probe Raw Values*  
Test menu with display of probe raw data
  - *Set Power Line Frequency (not for gauge models ISOSCOPE®)*  
Adjusting the frequency of the local voltage supply to compensate for the interference radiation emanating from the local voltage supply increases the measuring performance for the DUALSCOPE® and DELTASCOPE® gauge models
  - *Delete all calibrations*  
Deletes all calibrations from the memory of the connected probe; NOTE: You cannot measure without a calibration!
- *Gauge Settings > About*  
Information about the firmware version, copyright and connected probe

### 3.8 Statistical characteristic variables

$\bar{x}$  – *Mean Value*

Arithmetic mean value ( $\bar{x}$ ) of all measured readings. The arithmetic mean value is the summation of all measured readings  $x_i$  of a batch or block, divided by the number of measured readings ( $n$ ).

$n$  – *Number*

Number of all measured readings in a batch or per block.

$s$  – *Std. Dev.*

Standard deviation is a measure for the variation of individual measured readings (of a batch or block) around their common mean value ( $\bar{x}$ ). It equals the mean square deviation of the measured readings from the mean value.

$R$  – *Range*

The range equals the difference between the highest and lowest measured reading in a batch or block.

$V[\%]$  – *Coeff. of Variation*

Coefficient of variation, percentage variation of a series of measurements, i.e. stan-

standard deviation ( $s$ ) relative to the mean value ( $\bar{x}$ ). The coefficient of variation is a characteristic process constant. A sudden change in the coefficient of variation indicates a change in process conditions.

*Min – Low. Value*

Lowest measured reading in a batch or block.

*Max – High. Value*

Highest measured reading in a batch or block.

$<LSL - n < LSL$

Number of measured readings below the lower specification limit (LSL).

$>USL - n < LSL$

Number of measured readings above the upper specification limit (USL).

*No. – Block No. (No.)*

Number of the current/selected measured reading block.

## 3.9 Technical Data

### Description

With these gauge models you measure coating thicknesses easily, quickly, non-destructively and with the precision that is typical for all Fischer instruments.

This gauge family contains gauges for measurement on ferrous, electrically conductive base material, or both base material models.

### Universally

- Universal applicable coating thickness gauges
- Various probe models are connectable to the gauges, appropriate to your individual applications;  
Measurement range, trueness and repeatability are dependent on the connected probe. You will find this data in the respective probe data sheet.
- Uniform, simple and convenient operation
- Calibrations for various applications are storable in and recallable from the connected probe
- USB and Bluetooth® interface
- Compact and robust aluminium case with protection type IP64
- Battery rechargeable in the gauge or by a separate charger

### Models

DELTA  
SCOPE  
DMP30

ISO  
SCOPE  
DMP30

DUAL  
SCOPE  
DMP40

Convenience models with large data storage and expanded feature range as more measurement value storage, grouping measured readings, limit monitoring, measurement mode Scan and Bluetooth® interface

## Applications

Examples

### Base material steel or iron (FE)

- Zn, Cr, Cu coating on steel or iron (NF/FE)
- Paint, varnish, plastic coating on steel or iron (NC/FE)

### Base material electrically conductive (NF)

- Paint, varnish, plastic coating on Al, Cu or Brass (NC/NF)
- Anodized coating on Al (NC/NF)

	DELTASCOPE DMP30	ISOSCOPE DMP30	DUALSCOPE DMP40
Base material steel or iron (FE)	■		■
Base material electrically conductive (NF)		■	■

## Metrological Features

### Measurement acquisition

- Default: After each placement of the probe onto the surface, a measured reading is automatically recorded
- Scan mode: While probe is moving over the surface the measured readings are automatically recorded according to the defined time interval and number of measurements.

### Indication of measurement acquisition

- Audible by a short beep, can be disabled
- Visual by colored illuminated strip (green: measured value recorded)
- Haptic feedback by gauge vibration, can be disabled
- Limit violation: 2 short beeps, red illuminated strip and gauge vibration
- Measured reading between the limits: 1 short beep, green illuminated strip and gauge vibration

### Measurement performance

Measurement speed, measurement range, trueness etc. depend on connected probe, you will find these data in the respective probe data sheet

---

## Grouping measured readings

Block (group) size can be set between 1 and 1000 single readings

---

## Storage of measured readings

Can be disabled

---

## Measurement unit

$\mu\text{m}$ , mm, mils, pinch or customized unit (definable, related to  $\mu\text{m}$ ), selectable

---

## Limit Monitoring

Can be disabled; limit values can be set

---

## Offset value/ correction value

Can be set, is deducted automatically from the measured reading. Thus, one obtains the thickness of the top coating if for instance the interim coating is known.

---

## Resolution of the displayed values

- Low (up to 1 decimal place)
  - Medium (up to 2 decimal places)
  - High (up to 3 decimal places)
  - NAVSEA (1 decimal place for measured readings up to 254  $\mu\text{m}$  (10 mils), integer for measured readings as from 254  $\mu\text{m}$  (10 mils))
- 

## Measurement modes

### ■ Single Reading

After each placing of the probe, the measured reading is displayed and stored automatically in the gauge.

### ■ Free Running

After placing the probe on the surface, the continuous display of the measured readings appears without automatic storage, useful for quick checking of coating thicknesses over a defined surface area, e.g. in tank construction

### ■ Scan

The Scan mode allows a defined acquisition of the measured readings while the probe is moving over the surface. You can set the number of single readings and the time interval for the measurement acquisition in the gauge. Useful to determine the coating thickness over surface areas.

## Calibration

For a correct measurement of the coating thickness, the gauge must detect the properties (permeability, electrical conductivity, geometry) of the test piece. This adjustment is carried out by a calibration. Furthermore, the gauge contains a function for semi-automatic calibration.

### Calibration method

Adjustment of the measuring system (gauge and connected probe) to geometrical form and base material of the test piece (= Zero point determination) and adjustment to up to two coating thickness values by using calibration foils. On recalibration, individual calibration steps can be skipped.

### Store calibrations

The storage location for a calibration depends of the connected probe.

- Digital probe: up to 100 calibrations can be stored in the connected digital probe;  
probe identifiable by the USB-C female jack and by the probe name, always beginning with the letter D
- Analog probe: connection via DMP-F-probe-Adapter plugged into the gauge; a total of up to 100 calibrations can be stored in the DMP-F-Probe-Adapter; only the calibrations that were created with the probe connected to the DMP-F-Probe-Adapter are available in the gauge in each case.  
Probe identifiable by the 10-pin male jack and by the probe name, always beginning with the letter F or containing the letter F.

### Calibration check

Checking the calibration state of the selected calibration and the measuring accuracy of the measuring system. You can check whether the mean value of the check measurement matches the reference value of the calibration standard within the scope of measurement uncertainty (in accordance with ISO/IEC Guide 98-3).

### Lock calibrations

You can lock selected calibrations.

---

## Ways of air reference value acquisition

During measurement, the air reference value is used to reference the zero point determination. Regular measurement of the air reference value is necessary to achieve high measurement accuracy. This is done automatically in the measurement mode Single Reading when the probe is lifted off from the surface.

- Default in Probe: air value acquisition as factory predefined in probe (Dynamic/Static)
- Dynamic: automatic acceptance of the air value always when the probe is lifted from the surface, default mode
- Static: no automatic acceptance of the air value always when the probe is lifted from the surface. In this case, the air reference value must be measured manually at regular intervals. This may be useful for measurements in small cavities or pipes where the minimum lift-off distance of the probe cannot be maintained within cavity/pipe.

---

## General Features

---

### Measurement views

- Simple: the measured reading with the set measurement unit is displayed only; additionally with display of the limit values if set
- Statistics: the measured reading with tabular measurement statistics

---

### Languages

Many different display languages, beside German and English several other European and Asian languages

---

### Date & Time

- settable
- Date and time formats settable (DD.MM.YY or MM/DD/YY and 12 h or 24 h)

<b>Storage space</b>	DELTASCOPE DMP30	ISOSCOPE DMP30	DUALSCOPE DMP40
<b>Number of batches</b>	≤ 2500		
<b>Total number of measured readings</b>	≤ 250 000		
<b>Number of blocks per batch</b>	≤ 10 000		
<b>Number of meas. readings per block</b>	≤ 10 000		

<b>Evaluation</b>	DELTASCOPE DMP30	ISOSCOPE DMP30	DUALSCOPE DMP40
<b>Batch statistics</b> Evaluation of all stored measured readings of one batch	■	■	■
<b>Block statistics</b> Evaluation over the grouped measured readings, evaluation per block	■	■	■
<b>Graphical presentation of measured readings</b> Histogram of all measured readings of one batch, from 5 readings	■	■	■

<b>Data transmission</b>	DELTASCOPE DMP30	ISOSCOPE DMP30	DUALSCOPE DMP40
<b>via USB</b>	■	■	■
<b>via Bluetooth® only with Fischer Bluetooth® stick</b>	■	■	■
<b>Data export via Tactile Suite to Excel® (online, offline)</b>	■	■	■
<b>Data retrieval from Tactile Suite, batches, single readings, batch statistics,</b>	■	■	■
<b>Block statistics</b>	■	■	■

## Test methods

	DELTASCOPE DMP30	ISOSCOPE DMP30	DUALSCOPE DMP40
<b>DIN EN ISO 2178 / ASTM D7091</b> Magnetic induction test method, measurement of non-magnetic coat- ings on magnetic substrates	■		■
<b>DIN EN ISO 2360 / ASTM D7091</b> Amplitude-sensitive eddy current test method, measurement of non- conductive coatings on non-magnet- ic substrate metals		■	■

## Connectable probes

- Digital probes with USB-C female jack, probe names always beginning with the letter D
- Via DMP-F-Probe-Adapter many analog probes with 10-pin male jack; probe names beginning with the letter F or containing the letter F;
  - Probes connectable to the DMP-F-Probe-Adapter: F20H, FA100, FA14, FA30, FA70, FA9, FAW3.3, FD10, FD13H, FGA0.6H FGAB1.3, FGAB1.3T, FGABW1.3, FGB2, FGBW2, FKB10, FKB4, FTA2.4-MC, FTA2.4-SC, FTA3.3, FTA3.3-5.6, FTA3.3-5.6-HF, FTA3.3F-Cr, FTA3.3FG, FTA3.3H, FTD3.3, V7FKB4
  - Not supported probes: duplex probes (FDX10, FDX13H, FN4D) and special probes for special customer-specific applications

The Fischer probe program encompasses nearly 100 probes designed to ensure optimal results with highest accuracy for the widest range of measurement applications. At factory each individual probe is adjusted at several reference points with the greatest care to ensure the highest possible degree of trueness.

## Energy management

- **Power supply:** Li-Ion rechargeable battery, model RRC1130  
Nominal voltage: 3.8 V=  
Nominal capacity: 3880 mA, 14.7 Wh  
max. charge voltage: 4.35 V=  
max. charge current: 2.4 A

- **Energy saving** for longest battery life
  - Automatic gauge switch-off after a preset time period without operation (key use, data transfer or measurement acquisition)
  - Automatic dimming of the display brightness after a preset time period
- **Battery operating period**  
> 24 h with continuous measurement and about +20 °C (+68 °F) ambient temperature
- **Battery charging time**  
Temperature during charging: 0 ... +45 °C (+32 ... +113 °F)  
about 6 h by default  
about 3 h for fast charging

---

### Protection class

IP64, dust-protected, splash-water proof

---

### Admissible climatic conditions during storage and transport

We recommend to store and transport battery and gauge separately

- Gauge with/without Li-Ion rechargeable battery
- Indoor only
- Ambient temperature: -20 ... +60 °C (-4 ... +140 °F)
- Relative humidity: 5 ... 60 %RH at 20 °C (+68 °F), non-condensing

---

### Admissible climatic conditions during operation

- Ambient temperature: 0 ... +40 °C (+32 ... +104 °F)
- Relative humidity: 5 ... 85 %RH at 25 °C (+77 °F), non-condensing
- Altitude of location: up to 2000 m (6561.7 ft) (above sea level)
- Pollution degree: 3

---

### Visual indications

- Graphical display with automatic flip view (can be disabled) allows optimum reading in different measuring positions
- Colored illumination strip to signal measurement acquisition, limit violation and battery charging status

---

## Connections

- 2 USB female jacks, type C
  - USB 3.1, 900 mA/5 V=, at gauge bottom: for connecting digital Fischer probe
    - for fast charging the Li-Ion rechargeable battery in the gauge
  - USB 3.1, 500 mA/5 V=, at gauge top: for charging the Li-Ion rechargeable battery in the gauge
    - for connection to a PC for data transfer
    - max. cable length: 3 m (118 ")
- USB socket, type A, at gauge top
  - Specific for inserting Fischer Bluetooth® stick for data transfer via Bluetooth®  
Fischer Bluetooth® stick (scope of supply): Bluetooth v 4.0. LE, transmit power up to -27 dBm

---

## Weight

Gauge with rechargeable battery: 276 g (0.61 lb)

---

## Dimensions

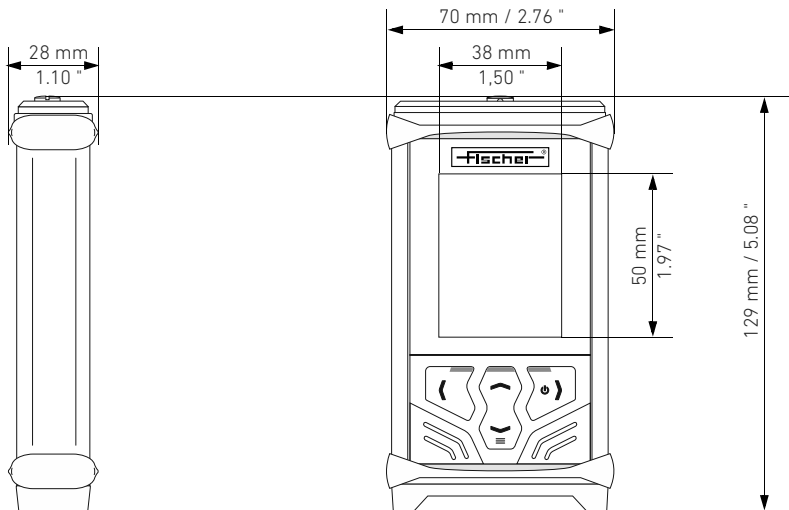

---

## Scope of supply

Gauge, Li-Ion rechargeable battery, USB cable type C to type A (1,5 m/59.06 "), safety information and quick guide, lanyard, gauge case, Fischer Bluetooth® stick

## Order Information

Gauge model	DELTASCOPE	ISOSCOPE	DUALSCOPE
	DMP30	DMP30	DMP40
Order number	1007331	1007332	1007333
Number of batches	≤ 2500		
Storage capacity	≤ 250 000 measured readings		
Vibration function	■	■	■
Grouping of measured readings	■	■	■
Bluetooth® interface	■	■	■
Accessories/Spare parts	DELTASCOPE	ISOSCOPE	DUALSCOPE
	DMP30	DMP30	DMP40
Manufacturer's Certificate M according to DIN 55350-18	in conjunction with probe only, see probe data sheet		
Evaluation and archiving software Tactile Suite	free of charge download, you will find download link in guide and manual on page 78		
DMP-F-Probe-Adapter for connecting analog probes with 10-pin connection plug	1007336		
Gauge support stand	1008201		
USB C cable, type C to A, 1 m (39.4 ")	1008215		
Fischer Bluetooth® stick	1008864		
Bluetooth v 4.0. LE, transmit power up to -27 dBm			
Li-Ion rechargeable battery model RRC1130	1008303		
Charger for battery model RRC1130	1008304		
Gauge foot	1005837		
Battery compartment cap	1007162		

You must order the probe separately. Choose the right probe for your individual application from our comprehensive probe portfolio. Call us, we are gladly support you with the selection.



## 4 Guide

All relevant settings for measuring the coating thickness of a coated specimen<sup>1</sup> and the measured readings themselves are saved in the gauge in a file. Such a file is called a batch. In order to measure, you must assign to the batch a calibration (reference) that is saved in the connected probe.



In the batch, you define the measurement procedure, e.g. whether specification limits are to be monitored during the measurement or whether the measured readings are to be acquired in measured reading block groups.

### 3 steps to the measurement



#### 1. Start-up the gauge

- Insert/charge the battery,  29
- Connect the probe,  33
- Switch on the gauge: press the [⏻] key for approx. 2 s.

#### 2. Open a batch or create a new one

- Open a batch:  > *Batches* > *OK* > select the desired batch from the batch list > *OK*
- Create a new batch,  37

#### 3. Take measurements on the specimen, 46

-  If the specified precision is not achieved during the measurement, you must check the calibration,  68.

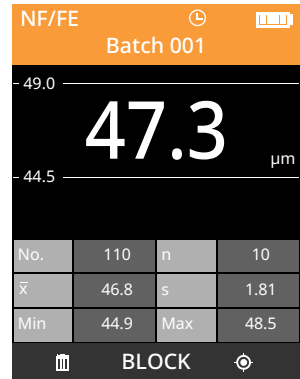

*Example of the Measurement view showing statistics with set specification limits*

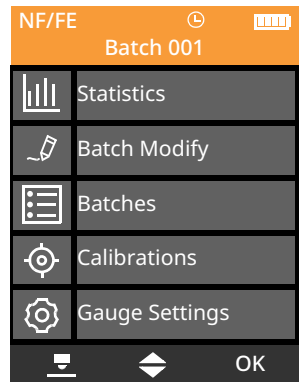

*Main menu (example: Batch 001 is open)*

1. In this Operator's Manual, both a coated part of any shape and size and a surface containing multiple measuring positions are referred to as a specimen.

## 5 Rechargeable battery

This chapter contains important instructions on handling, changing and charging the battery.



### CAUTION – when handling the battery

Improper handling of the battery can cause the battery to overheat, leak or burst.

- ▶ Use only batteries specified by the manufacturer to operate this gauge:  
Type RRC 1130 (3.8 V, 14.47 Wh, scope of supply)
- ▶ Prevent metal objects such as necklaces, rings, etc. from short-circuiting the contacts.
- ▶ Do not continue to use the battery if you notice any changes such as discoloration, deformation or damage to the outer casing.
- ▶ Replace the battery if it is not charged after the usual charging time. The usual charging time can be found in the technical data.
- ▶ Do not expose the battery to excessive heat, moisture or direct contact with water.
- ▶ Store the gauge with out the battery when not in use for a long period of time.

### 5.1 Changing the battery

Before you start

- The gauge is switched off ([⏻]).

## To change the battery

1.

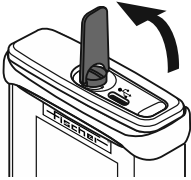

2.

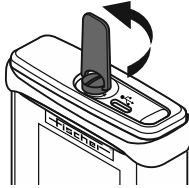

3.

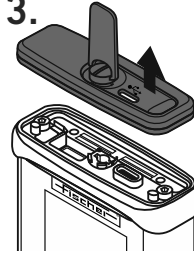

4.

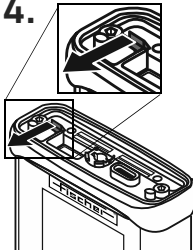

5.

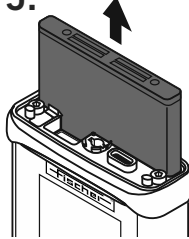

6.

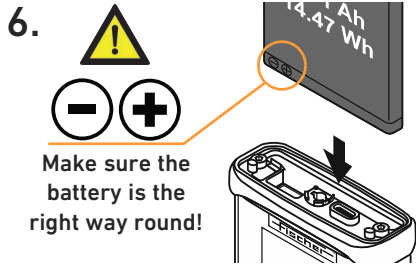

7.

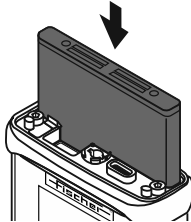

8.

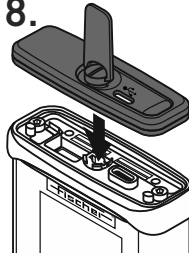

9.

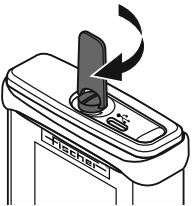

10.

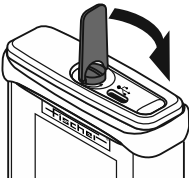

## What you can do next

- Charge the battery using the charger (available from Fischer as an accessory) for battery type RRC 1130
- Continue the measurement
- Make settings for the measurement; for an overview, see page 37

## 5.2 Charging the battery

### ! ATTENTION –Make sure the charging power is correct

Whether you use a standard travel charger or an external charger, always make that the battery is charged to the correct power:

Nominal voltage: 3.8 V=

Nominal capacity: 3880 mA, 14.7 Wh

max. charge voltage: 4.35 V=

max. charge current: 2.4 A

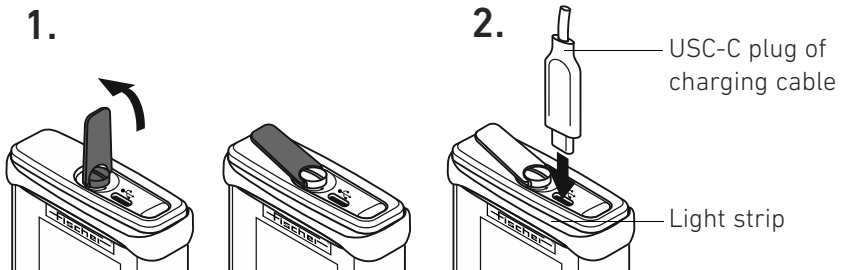

### To charge the battery

- Standard – charge the battery using a commercially available charger:
  - ▶ Do this by inserting the USB-C plug of the charging cable on the top of the gauge into the USB-C socket under the locking tab. Battery charging time is approx. 6 h. A green light strip on the switched-off gauge signals the end of the charging process.

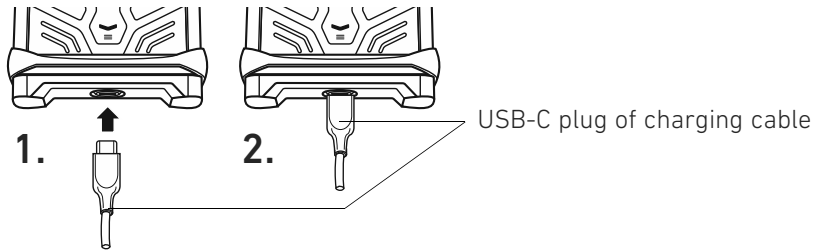

- Alternative 1 – quick charging using a commercially available travel charger:
  - ▶ Insert the USB-C plug of the charging cable into the USB-C socket on the underside of the gauge (probe connection).  
Battery charging time is approx. 3 h, a green light strip on the switched-off gauge signals the end of the charging process







- Alternative 2 – charge the battery using an external charger for model RRC1130 (available from Fischer as an accessory).
  - a Switch off the gauge, .
  - b Remove the battery from the gauge,  29.
  - c Refer to the safety Information on page 29.
  - d Place the battery in the external charger.  
Instructions for handling the external charger can be found in the Operator's Manual concerned.

## 6 Connecting/replacing probe

Every probe has its own identifier, consisting of a probe code (e.g. D-FN) and the serial number. Each time a batch (measuring application, application) is created, the probe identifier is automatically saved as well. This ensures that for the open batch, a measurement can be performed only using the probe that has the same identifier as the one saved in the open batch. As a result, the correct calibration is available for the batch and for the measurement.

What would you like to do?

- Connect a new probe as a replacement for a defective one: proceed as described in chapter "Replacing the probe – connecting a different probe",  35.
- Connect a different probe type to the one previously used: proceed as described in chapter "Replacing the probe – connecting a different probe",  35.
- Connect a new probe not yet used to create a batch in the gauge:
  - a Connect the probe as described in chapter "Connecting the probe", page 33.
  - b Create a new batch, proceed as described in  37
- Connect a probe already used to create one or multiple batches in the gauge:
  - a Connect the probe as described in chapter "Connecting the probe", page 33.
  - b Open the desired batch, proceed as described in  38

### 6.1 Connecting the probe



#### Notes on safe secure measurement signal transfer

- Always tighten the knurled nut on the probe cable connector firmly to ensure a secure plug connection!
- We guarantee flawless measurement signal transmission from the probe to the gauge for a cable length of max. 3 m (118.1 ").
- Extending the probe cable to 3 m (118.1 ") using a USB-C extension cable is not permitted, as the additional plug connection could impair the signal transmission.

## Before you start

- The gauge is switched off ([⏻]).

## To connect the probe to the gauge

- **Digital probes** (D...) with USB-C connecting socket, USB-C connection cable included in the scope of supply

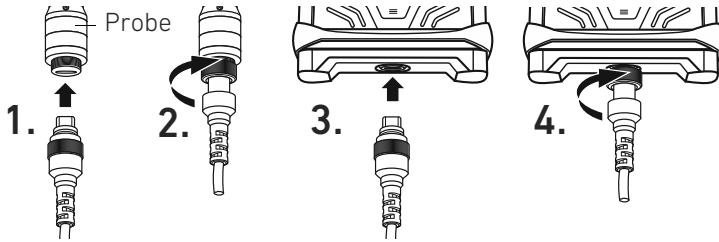

- **Analog probes** (F...) with 12-pin connecting plug via DMP-F probe adapter (1007336, available from Fischer as an accessory)

- To attach the DMP-F probe adapter to the gauge.

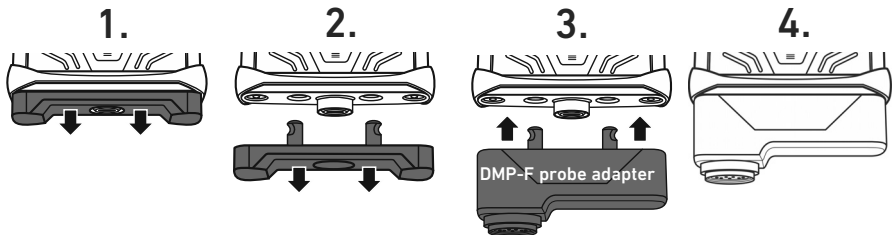

- To connect the probe to the DMP-F probe adapter.

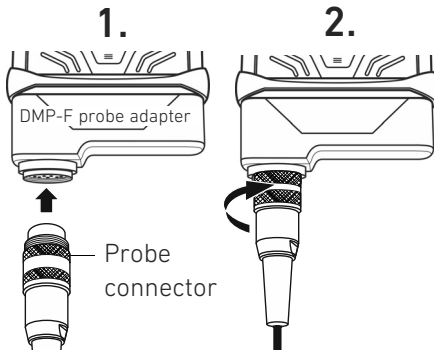



## 6.2 Replacing the probe – connecting a different probe

You can replace a defective probe with a new probe of the same type or connect a different probe type to the one previously used.

### **ATTENTION – Data loss**

If a new probe is assigned to a batch, all previous measured readings of the batch will be lost since the measured readings previously stored in the batch were measured using a different probe and a different calibration.

 For data backup, save the batch or the previous measured readings of the batch in Tactile Suite,  the link for download and further information can be found on page 78.



### **Refer to the following notes whenever you want to replace a defective probe**

- You cannot transfer the calibrations from the old, defective probe to the new replacement probe.
- With the new probe, you must perform the required calibrations and store them in the probe. This requires the new probe to be assigned once to the open batch. You can create the calibrations you need in the calibration menu and save them in the new probe.
- You must assign the new probe to all batches created using the old, defective probe, as well as the corresponding calibrations from the new probe.
- If the probe connected to the DMP-F-Probe-Adapter is a replacement, we recommend deleting all calibrations from the old, defective probe from the DMP-F probe adapter before assigning the new replacement probe. This prevents the unusable calibrations from the old, defective probe unnecessarily taking up memory space in the DMP-F-Probe-Adapter, , delete all calibrations from the probe, see page 74.

### Before you start

- The gauge has been switched off () and a batch created with the old (defective) probe was opened beforehand.

### To assign the connected probe to the open batch

1. Connect the new probe to the gauge,  33.
2. Switch on the gauge: .

3. Open the most recently opened batch: .

4. The *Reassign probe?* menu page appears.

The menu page displays the probe identifiers of the two probes: the old one previously assigned to the batch, and the connected new probe.



5. Assign the connected probe to the batch: *OK*.

A message tells you that a calibration still needs to be assigned to the open batch.

6. What would you like to do?

- Assign a calibration from the connected probe to the open batch:  > select desired calibration > *OK*.

This completes the process and the Measurement view of the open batch appears.

- Perform a new calibration for the open batch:  > *New* > follow the calibration routine,  for the procedure, see page 66.

This completes the process and the Measurement view of the open batch appears.

- Do not assign a calibration to the open batch: *OK*

This completes the process and the main menu appears.

 Please note that a measurement is possible only if a calibration has been assigned to the batch.

## 7 Settings for measurement

In order to measure, you need to create and open a batch (measuring file). Settings, such as those for the measurement procedure are saved in the batch, e.g. specification limit monitoring and grouping of measured readings in measurement blocks during the measurement and in measuring mode. The link to the calibration to which the measurements are referenced is also stored in the batch file.

If any parameter changes, there is a new measuring application and you have to create a new batch.







- A description of the possible batch settings you have to make before a measurement can be found below.
- A description of the batch settings, which you can also make after a measurement, can be found from page 82.

### 7.1 Creating a new batch

You can create a batch in the following ways:

#### Create a new batch from scratch

In this case, you must make all the required measurement settings again.

1.  > *Batches* > *OK* > *New* > Select a calibration from the list or *New* from > *OK*
2. Have you selected a calibration from the list?
  - No: Continue with step 3.
  - Yes: Continue with step 4.
3. Follow the calibration routine and finish each calibration step via *OK*. You can also skip the last calibration step (Std. 2) via ,  62.
4. Make the desired batch settings for the measurement  38, assign a batch name,  88  
This completes the creation process for a new batch.
5. Call up the Measurement view for the new batch: *MEASURE* > *OK*.

## Creating a new batch by copying

You use the *Copy* function to create a batch by copying a selected batch. Apart from the measured readings and the batch name, the batch copy contains all the settings of the batch copy template.

- ▶  > *Batches* > *OK* > select a batch as a copy template from the list > *OK* > *Copy* > *OK* > The Measurement view of the newly created batch appears in the display



- Measurement settings, see from page 38
- Assign calibration, see page 44
- Check calibration, see page 68
- Rename a batch, see page 88

## 7.2 Opening a batch

- ▶  > *Batches* > *OK* > select desired batch from the batch list > *OK*  
The Measurement view of the selected batch appears in the display.



- Measure, see from page 46
- Check calibration, see page 68

## 7.3 Activating/deactivating specification limit monitoring

Before you start

- The batch for which you want to make the changes is open in the gauge.

To activate specification limit monitoring and set the specification limits

1. Select the specification limits to be monitored:  > *Batch Modify* > *OK* > *Limits* > *OK* > select desired specification limit parameter > *OK*.

Parameter is activated: ●

The selected specification limit(s) with the currently set values appear in the specification limit menu.

2. Set the specification limit: select specification limit > *OK* > set desired value > *OK*.

Repeat step 2 for the second specification limit, provided you have selected *Both* in step 1.

3. Exit the menu: , the settings are now made

**i** In the Measurement view, lines with the entered specification limits appear above and below the measured reading or a line appears below the measured reading with the entered limit value.

## To deactivate specification limit monitoring

1.  > *Batch Modify* > *OK* > *Limits* > *OK* > *Off* > *OK*

Parameter is activated:

2. Exit the menu: , specification limit monitoring is deactivated.

## 7.4 Activating/deactivating automatic block formation

You can automatically group a predefined number of measured readings into measured reading blocks. Activate automatic block formation to form a block closure automatically after a specified number of measured readings during the measurement.

### Before you start

- The batch for which you want to make the changes is open in the gauge.
- The open batch does not contain any measured readings.

### To activate automatic block formation and set the desired block size



1.  > *Batch Modify* > *OK* > *Block Size* > *OK* > *Generate autom.* > *OK*.

Parameter is activated:

2. Set the block size: *Block Size* > *OK* > set desired value > *OK*.

3. Exit the menu: , the settings are now made.

## To deactivate automatic block formation

1.  > *Batch Modify* > *OK* > *Block Size* > *OK* > *Generate autom.* > *OK*.  
Parameter is deactivated: 
2. Exit menu: , automatic block formation is deactivated.

## 7.5 Activating/deactivating offset function



You can correct the measured reading by a pre-defined offset value. The actual measured reading less the offset value is displayed.



Application example: coating thickness measurement on a 2-coating system with known intermediate coating thickness that is entered as the offset value. Only the thickness of the top coating is then displayed.

### Before you start



- The batch for which you want to make the changes is open in the gauge.

### To activate the offset and set the offset value

1.  > *Batch Modify* > *OK* > *Offset* > *OK* > *On* > *OK* > set desired offset value > *OK*  
Parameter is activated: 
2. Exit the menu: , the settings are now made.

 The  icon appears in the Measurement view to indicate the active offset function.

### To deactivate the offset function

1.  > *Batch Modify* > *OK* > *Offset* > *OK* > *Off* > *OK*  
Parameter is deactivated: 
2. Exit the menu: , the offset function is deactivated.

## 7.6 Selecting measuring mode

You can specify how the measured readings are to be acquired and displayed.

### **Single Readings** (default mode)

Measured reading acquisition after the probe is placed on the surface. The measured readings are automatically saved in the batch (measurement file), provided the *Save Readings* function is activated.

### **Free Running**

Continuous measured reading display while the surface is being scanned with the probe. Measured readings are not saved even if the *Save Readings* function is activated!

Select *Free Running* measuring mode if you want only an overview of the coating thickness distribution.

### **Scan**

Defined measured reading acquisition while the surface is being scanned with the probe. You can set the number of measured readings and the interval time for measured reading acquisition in the gauge. The measured readings are automatically saved in the batch (measurement file), provided the *Save Readings* function is activated.

- *Unlimited*

According to the time interval set in the *Scan* measuring mode menu, a measured reading is acquired and saved every x seconds as the surface is being scanned. Automatic measured reading acquisition is stopped by lifting off the probe. This function is not suited for non-stop operation, see also notes on page 46.

- *Limited Number*

According to the parameters (time interval, number of measured readings to be acquired) set in *Scan* measuring mode, a measured reading is acquired every x seconds as the surface is being scanned. After n measured readings, automatic measured reading acquisition stops. The measurement cycle is repeated when the probe is applied again.

- *Counted Average*

An arithmetical mean is formed from the individual measured readings continuously acquired as the surface is being scanned, and this value is saved and used for the further evaluation. Automatic measured reading acquisition is stopped by lifting off the probe.

- *Limited Number Block*



Available only when automatic block formation is activated. According to the



parameter (time interval) set in *Scan* measuring mode, a measured reading is acquired every x seconds as the surface is being scanned. After n measured readings, automatic measured reading acquisition stops. The measurement cycle is repeated when the probe is applied again. The setting for the number of measured readings per block in the *Block Size* is used as the number of measured readings.

## Before you start

- The batch for which you want to make the changes is open in the gauge.

## To select a measuring mode

1.  > *Batch Modify* > *OK* > *More Settings* > *OK* > *Measure Mode* > *OK* > select desired mode > *OK*  
Parameter is activated:
2. Have you selected the *Scan* measuring mode?
  - No: continue with step 6.
  - Yes: Continue with step 3.
3. Select the *Scan Mode* on the page with the same name: *Scan Settings* > *OK* > select the desired *Scan Mode* > *OK*  
Parameter is activated:
4. Have you selected the *Scan Mode Counted Average*?
  - No: continue with step 6.
  - Yes: Continue with step 5.
5. Set the interval time and, if required, the number of measured readings: *Interval time [s]* > *OK* > set desired value > *OK*.  
Repeat step 5. for the *Number of Readings* parameter, provided you have selected 3. *Limited Number* in step.
6. Exit the menu: , the settings are now made.

 In the Measurement view, depending on the measuring mode selected, the corresponding icon appears to indicate the active function, a description of the icons  can be found on 9.

## 7.7 Save measured readings on/off

You can specify whether the measured readings are automatically saved in the open batch.

### Function activated (default mode)

The measured reading is automatically saved in the open batch with every measured reading acquisition.

### Function deactivated

The measured readings are automatically saved in the open batch only temporarily. When a different batch is called or the gauge is switched off, the measured readings are lost.

### Before you start

- The batch for which you want to make the changes is open in the gauge.

### To activate/deactivate the save measured reading function

1.  > *Batch Modify* > *OK* > *Save Readings* > *OK*

Parameter is activated: 

Parameter is deactivated: 

2. Exit the menu: , the setting has now been made.

 The Measurement view shows the  icon to indicate that the measured reading save function has been deactivated.

## 7.8 Air reference value – automatic/manual acquisition

The air reference value references the zero point determination for the measurement.

- Zero point determination: measurement on the uncoated base material = coating thickness 0 (normalization, zero)
- Air reference: Measurement in air = coating thickness infinite = saturation = air reference value

To achieve a high measurement accuracy, the air reference value has to be measured on a regular basis.

You can choose between automatic (dynamic) and manual (static) acquisition of the air reference value:

**Dynamic** (default mode)

Dynamic, automatic acquisition of the air value each time the probe is lifted off the surface.

**Static**

Static, no automatic acquisition of the air value each time the probe is lifted off the surface. The air reference value has to be measured manually at regular intervals. Useful for measurements in small cavities or pipes where the minimum lift off distance of the probe cannot be maintained within the cavity/pipe.



**Default in Probe**

Information about the acquisition method for the air reference value set in the probe in the factory.

Before you start

- The batch for which you want to make the changes is open in the gauge.

To change the acquisition method for the air reference value

1.  > *Batch Modify* > *OK* > *More Settings* > *OK* > *Air Reference* > *OK* > set service code (159) > *OK* > set desired acquisition method > *OK*  
Parameter is activated:
2. Exit the menu: , the setting has now been made.

## 7.9 Assigning a different calibration to the opened batch

Before you start

- The batch for which you want to make the change is open in the gauge.

## To assign a different calibration to the open batch

- ▶  > *Batch Modify* > *OK* > *More Settings* > *OK* > *Calibration Assign* > *OK* > select the desired calibration from the list > *OK*

A different calibration has now been assigned.

## 8 Measure

### 8.1 Notes on measuring

- The information for precision (remaining deviations from precision to measured reading) and repeatability (repeated standard deviation) applies for the ambient and reference piece temperatures at the time of the calibration. The values for precision and repeatability may be higher than the values indicated in the data sheet if the temperatures during the measurement deviate from the ambient and reference piece temperatures during the calibration.
- Rough surfaces: For measurements on rough surfaces, we recommend grouping the measured readings into blocks and working with the block mean values for further evaluation. This minimizes the measured reading variation in the evaluation that follows.
- As a basic rule: If the specified precision is not achieved during the measurement, you must check the calibration recalibrate the probe if necessary.
- If all signal functions in the gauge are activated, the gauge reports the following states:

#### Beeps

- Short beep = measured reading acquisition complete, second beep in addition if the specification limit is violated
- Long beep = block closure

#### Light signals

- Specification limit monitoring not active:  
Green = measured reading acquisition successful
- Specification limit monitoring active:  
Red = measured reading outside the specification limits, the measured reading itself is also displayed in red.

#### Gauge vibration

- Measured reading acquisition completed, second vibration in addition in case of a specification limit violation or block closure

- For the following measurement situations, we recommend setting the acquisition of the air reference value to *Static*:
  - Measurements in cavities and pipes if the minimum lift off distance of 4 x the probe measurement range cannot be respected,  53
  - Measurements in *Scan* measuring mode with a very high number of measured reading acquisitions while the surface is being scanned

## 8.2 Handling the probe

In addition to the calibration, the way in which the probe is placed on the surface is also crucial for a precise measurement. Measured reading acquisition via the probe.

-  Important notes for correctly handling the probe during the measurement
  - Always hold the probe at its grip sleeve.
  - Always place the probe perpendicular and gently on the surface.
  - For the measurement, place the probe quickly on the surface, do not allow the probe to hover over the specimen.
  - In default mode, a beep and a green light strip signals that the measured reading has been acquired. Only then lift the probe off the surface, lift off distance  $\geq 4 \times$  the probe measurement range.
  - Two-tip probe: For specimens whose base materials have a magnetic preferred direction, we recommend determining the measured reading by taking the average of two measurements, whereby the probe is to be rotated by  $90^\circ$  after the first measurement. Not relevant for the ISOSCOPE® gauge models.

## 8.3 Before you start

- The measuring area and the probe tip on the probe are clean, free of oil, dust, etc.
- The probe is connected to the gauge.
- The gauge is acclimatized and the battery are sufficiently charged for the upcoming measurement.
- The desired batch is open in the gauge with the correct measurement settings.

- In the event of an online data transfer during the measurement, connections suitable for Tactile Suite are configured.

During the measurement, you can also perform the following actions in the Measurement view

- Delete single/all measured readings or a measured reading lock that has not been closed: press the  key.
- View the statistics of the open/last measured reading block: press the *BLOCK*-key
- Set block closure manually: *BLOCK > CLOSE*, available only when automatic block formation is deactivated

## 8.4 Measuring in single reading measuring mode - procedure

### Measuring on flat specimens - single-tip probe

The display screens should be considered only as examples, the gauge default modes are required here for the measured reading acquisition, probe D-FN is shown as a typical example of our axial probes

#### 1. Position the gauge

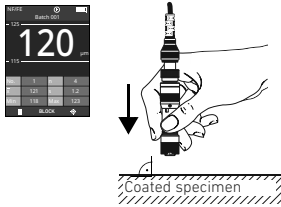

#### 2. Measured reading acquisition

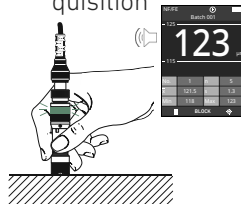

#### 3. Lift off the probe

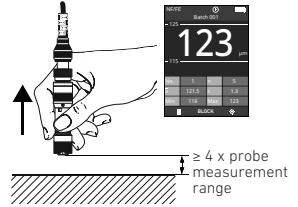

### Measuring on cylindrical specimens - single-tip probe

The display screens should be considered only as examples, the gauge default modes are required here for the measured reading acquisition, probe D-FN is shown as a typical example of our axial probes

#### 1. Position the gauge

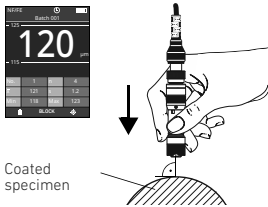

#### 2. Measured reading acquisition

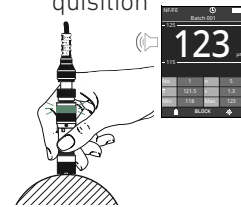

#### 3. Lift off the probe

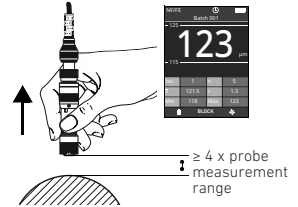

## Measuring on flat specimens - two-tip probe

The display screens should be considered only as examples, the gauge default modes are required here for the measured reading acquisition, probe D-F90-2t8 is shown as a typical example of a 2-tip probe

### 1. Position the gauge

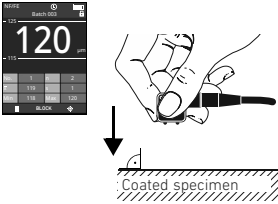

### 2. Measured reading acquisition

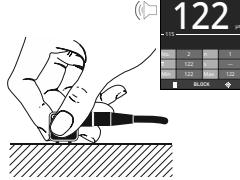

### 3. Lift off the probe

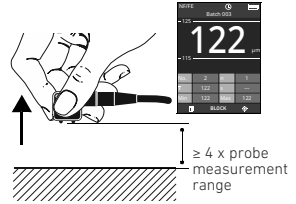

Additional measurement with 90° rotated probe when measuring on specimens with magnetic preferred direction.

### 4. Rotate probe through 90°

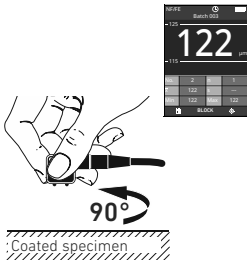

### 5. Position the probe

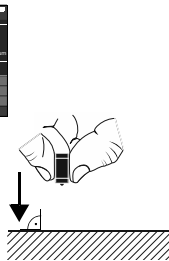

### 6. Acquire the measured reading

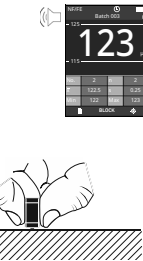

### 7. Lift off probe

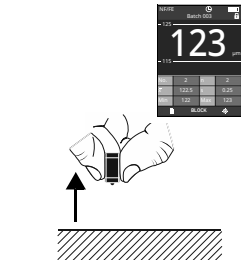

## Measuring on cylindrical specimens - two-tip probe

The display screens should be considered only as examples, the gauge default modes are required here for the measured reading acquisition, probe D-F90-2t8 is shown as a typical example of a 2-tip probe

### 1. Position the gauge

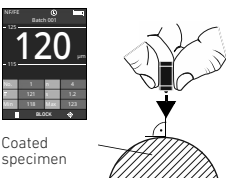

### 2. Measured reading acquisition

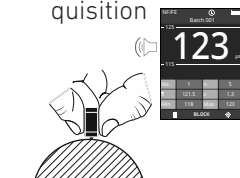

### 3. Lift off the probe

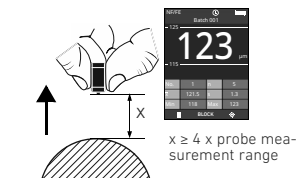

## 8.5 Measuring in free-running measuring mode - procedure

**i** No measured readings are saved!

### Measuring on flat specimens

The display screens should be considered only as examples, the gauge default modes are required here for the measured reading acquisition, probe D-FN is shown as a typical example of any probe

#### 1. Position the gauge

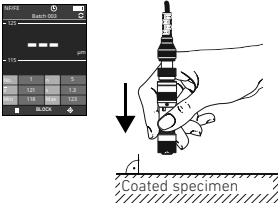

#### 2. Measured reading display

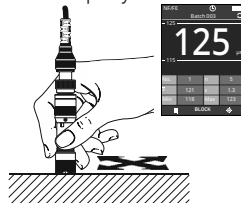

#### 3. Lift off the probe

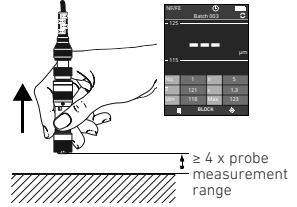

### Measuring on cylindrical specimens - single-tip probe

The display screens should be considered only as examples, the gauge default modes are required here for the measured reading acquisition, probe D-FN is shown as a typical example of our axial probes

#### 1. Position the gauge

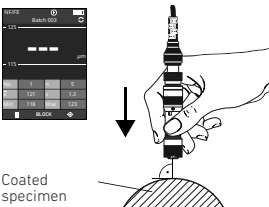

#### 2. Measured reading display

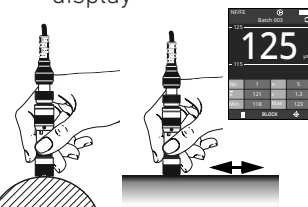

#### 3. Lift off the probe

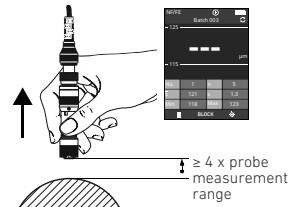

### Measuring on cylindrical specimens - two-tip probe

The display screens should be considered only as examples, the gauge default modes are required here for the measured reading acquisition, probe D-F90-2t8 is shown as a typical example of a 2-tip probe

#### 1. Position the gauge

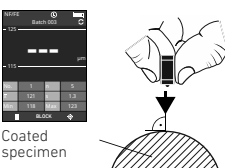

#### 2. Measured reading acquisition

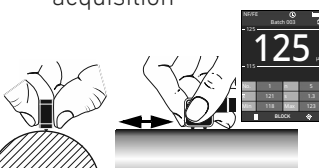

#### 3. Lift off the probe

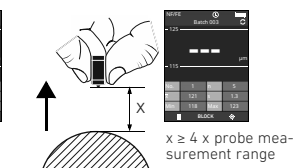

## 8.6 Measuring in scan measuring mode - procedure

### Measuring on flat specimens

The display screens should be considered only as examples, the gauge default modes are required here for the measured reading acquisition, probe D-FN is shown as a typical example of any probe

#### 1. Position the gauge

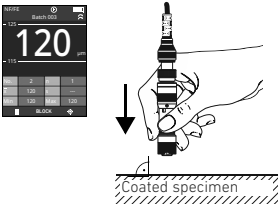

#### 2. Measured reading acquisition

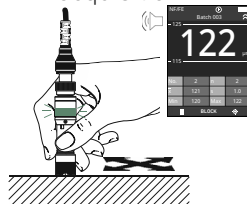

#### 3. Lift off the probe

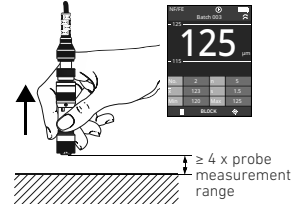

### Measuring on cylindrical specimens - single-tip probe

The display screens should be considered only as examples, the gauge default modes are required here for the measured reading acquisition, probe D-FN is shown as a typical example of our axial probes

#### 1. Position the probe

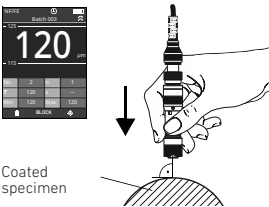

#### 2. Measured reading acquisition

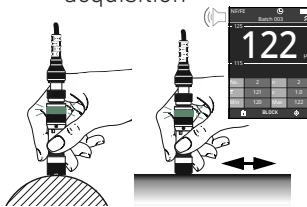

#### 3. Lift off the probe

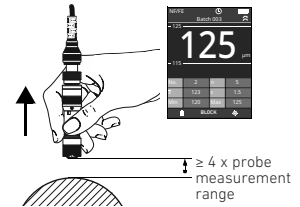

### Measuring on cylindrical specimens - two-tip probe

The display screens should be considered only as examples, the gauge default modes are required here for the measured reading acquisition, probe D-F90-2t8 is shown as a typical example of a 2-tip probe

#### 1. Position the gauge

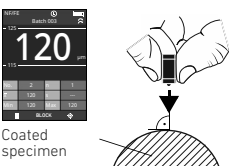

#### 2. Measured reading acquisition

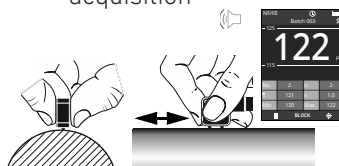

#### 3. Lift off the probe

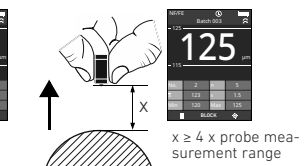



## 8.7 Measuring with manual recording of the air reference value

If the minimum lift off distance of 4 x the probe measurement range cannot be maintained when measuring in cavities and pipes, you can also record the air reference value manually at regular intervals.

### Before you start

- Air value recording is set to Static,  43
- Refer to the notes on measurement at the beginning of this chapter
- The batch is open, the Measurement view can be seen in the display.

### To measure with manual recording of the air reference value

1. Perform your measurements as described in the previous chapters.  
We recommend recording the air reference value at regular intervals, e.g. between each specimen or after every 10th specimen.
2. Record the air reference value:  > hold the probe in the air > OK > .
- The manual recording of the air reference value is now complete.
3. Repeat steps 1. and 2. for subsequent measurements.

## 9 Calibration

The term "calibration" is used in this Operator's Manual as a general term for determining the deviation from a reference value, adjustment and correction: calibration of the gauge using calibration standards to adapt the measuring system (gauge and probe) to the measuring application at hand.

The calibration sets the difference between nominal and actual value to zero.

A calibration is a reference measurement during which the material properties and geometric shape of the specimen are recorded and stored in a calibration file in the connected probe, separate from the batch. During the reference measurement, the influencing variables are recorded using an uncoated reference piece and one or two calibration standards in order to compensate the influences for future measurements.

- Uncoated reference piece, the material of which has the same properties as the base material of the specimen. Needed for adjustment to the base material (zero = zero point).
- Calibration standard, available in different versions:
  - Calibration foil, plastic foil, hard paper foil or metal foil with a certain thickness, characterized by the nominal value that simulates a coating thickness during the calibration process. An adjustment to the corresponding coating thickness value is performed for each calibration foil thickness.
  - Calibration standard, coated reference piece whose base material and coating material have the same properties as the coated specimen and whose coating thickness has been determined using the most accurate alternative measurement method possible (nominal value of the calibration standard).

In order to measure, it is absolutely essential that a calibration suitable for the measuring application has been assigned to the batch.

The coating thickness measurement is mainly influenced by the following variables:

- Physical properties of the base material of the specimen, such as magnetizability (permeability) or electrical conductivity
- Geometric shape of the specimen, such as the thickness of the base material or the curvature of the specimen (e.g. cylindrical shape)

- Position of the measuring position on the specimen, such as distance from the edge, hole, platform, or step
- Surface roughness

## 9.1 Overview of calibration methods

### **Zero** (zero point, calibration step *Zero*)

This is the simplest type of calibration and is used to calibrate the gauge to a reference point, the base material, which is called zero here (zero point). The measurement is taken on a reference piece that has the same material and shape as the actual uncoated specimen to be tested. It consists only of the specimen base material (magnetizable (FE) or non-magnetizable (NF), depending on the test method used).

### **Zero + 1 standard** (calibration steps *Zero* and *Std. 1*)

A calibration using a calibration standard achieves the best measurement accuracy in a narrow measurement range around the stated standard thickness. The calibration method Zero + 1 standard can be used only in the lower measurement range of the gauge.

You can find the values available for the calibration standard in the probe data sheet.

### **Zero + 2 standards** (calibration steps *Zero*, *Std. 1* and *Std. 2*)

On the one hand, a calibration with 2 calibration standards achieves the best measurement accuracy in the measurement range that is limited by the two calibration standard values; on the other hand, however, 2 calibration standards are needed to calibrate the upper measurement range of the gauge.

For a calibration with 2 foils, you can find the foil pairings in the probe data sheet.

## 9.2 Please observe the following information on calibration/ recalibration

- The reference piece and specimen must have the same base material properties.
  - The positions of the measuring position on the reference piece and on the specimen to be measured must be roughly the same (curvature, distance from the edge, hole, platform, and step).
  - The information for precision (remaining deviations from precision to measured reading) and repeatability (repeated standard deviation) applies for the ambient and reference piece temperatures at the time of the calibration. The values for precision and repeatability may be higher than the values indicated in the data sheet if the temperatures during the measurement deviate from the ambient and reference piece temperatures during the calibration.
  - If measurements are to be performed on both magnetizable (FE) and non-magnetizable (NF) base materials, the calibration must be performed using both base materials (FE and NF)! This is useful when using a dual probe, such as FD13H and D-FN.
  - Treat the calibration standards = calibration foils with care. Replace soiled, bent, scratched or cracked calibration foils or those with severe indentations. In particular foils with thicknesses of less than 50  $\mu\text{m}$  (2 mils) are subject to rapid wear. Recommendation: replace the calibration foils after no more than 100 to 200 measurements!
  - Perform the calibration with care! This is the benchmark for the accuracy to which the following measurements can be performed. – Measurements can never be more accurate than the calibration itself!
- ❗ Do not use the metal sheet (NF/FE or ISO/NF) supplied with the gauge as a reference piece! As a rule, the material properties of the metal plate will not correspond to those of your own uncoated specimen/reference piece! The metal plate(s) serve only to check the function of the gauge!
- ❗ Calibration on NF base material (NF = non ferromagnetic base material): the difference between the reference piece temperature during the calibration and the specimen temperature during the measurement should be minimal. Excessive temperature differences have an adverse effect on the measurement accuracy.

### 9.3 Calibration – when is it necessary?

#### New calibration – when is it necessary?

- When there is a new specimen, the properties for which no calibration has yet been created. In this case, you have to record the influencing variables with a new calibration in order to compensate for them when measuring.
- For measurements on magnetizable base material (FE), it makes sense to perform a calibration with at least 1 calibration standard.
- If the specimen has a very low (e.g. titanium, stainless steel) or very high (e.g. copper, silver) electrical conductivity when measured on non-magnetizable base material (NF), we recommend performing a calibration with at least 1 calibration standard here as well.

#### Recalibration – when is it necessary?

- The measurement does not achieve with the specified degree of precision.
- The check of the current calibration delivers a negative result.



### 9.4 Recalibration

A recalibration is in effect the repeat of an existing calibration. The calibration data are overwritten when a calibration routine is run again.







During the recalibration, you can skip individual calibration steps (*Zero* or *Std. 1/2*).

- i** In the case of rough surfaces, it may be advisable to skip the *Zero* calibration step during the recalibration. Repeat measurements on the rough base material do not usually deliver better values. However, if the permeability of the specimen base material has changed, you must perform the *Zero* step on the base material with the changed permeability!

## Before you start

- Refer to the notes on calibration,  56
- The probe in which the calibration to be recalibrated is stored is connected to the gauge.
- Reference piece and/or calibration foils are ready. You can find the parts you need on the calibration info page:  > *Calibrations* > *OK* > select name of calibration > *OK* > *Info*.
- If the calibration you want to repeat is locked, you need to know the lock code.

## To repeat an existing calibration

1. Open the calibration to be repeated:
  - Open a calibration from the list:  > *Calibrations* > *OK* > select name of calibration > *OK* > *CALIBRATE*.
  - Open the calibration used in the open batch:  (in the Measurement view).
2. Prompted to set the lock code?
  - Yes: Set the lock code and deactivate the lock function,  73  
function is deactivated: 
  - No: Continue with step 3.
3. Follow the routine and perform the calibration steps (Zero, Std. 1/2).
  - a "Calibration step Zero – Procedure",  59
  - b "Calibration step Std – procedure",  61



### Notes

- If the *Shortened course* function is activated, the calibration routine switches automatically to the next calibration step after every 3 measurements. It is not possible to correct/change the specified calibration foil when this function is activated.
- If you have deactivated the lock function for recalibration, do not forget to reactivate the lock function before exiting the calibration menu,  72.

## 9.4.1 Calibration step Zero – Procedure

Measure on the uncoated reference piece.

### Required material

- Base material FE: ferromagnetic material = FE = ferrous reference piece from customer's own production, without the coating to be measured; NF/FE display screen
- Base material NF: non-ferromagnetic, electrically conductive material = NF = non-ferrous, electrically conductive reference piece from customer's own production, without the coating to be measured; NC/NF display screen

### To perform the zero calibration step Zero

1. Perform 5 to 10 measurements on the uncoated reference piece.

#### A Position the gauge

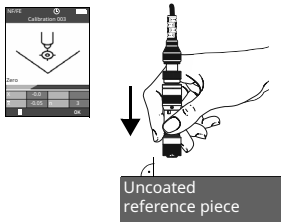

#### B Measured reading acquisition

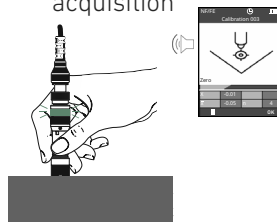

#### C Lift off the probe

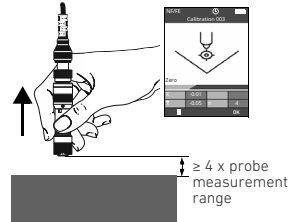

The display screens should be considered only as examples, the gauge default modes are required here for the measured reading acquisition.

Repeat Steps A to C for the subsequent measurements on the uncoated reference piece.

2. Finish the calibration step Zero: OK.

3. What would you like to do?

▶ Finish the calibration: 1 x ↻

The measuring system is now calibrated to the base material and the part geometry (= Zero = zero point), the calibration is finished, the calibration menu with the calibration list appears in the display

▶ Continue the calibration with calibration standard(s): continue with "Calibration step Std – procedure", 📖 61

## Display description – Zero calibration step

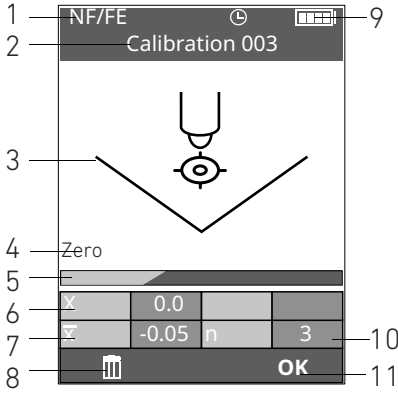
- |  |  |
|--|--|
| <ol style="list-style-type: none"> <li>1 Base material currently being measured (example FE)</li> <li>2 Name of calibration (example)</li> <li>3 Schematic illustration of the current calibration step</li> <li>4 Current calibration step</li> <li>5 Progress display of the calibration steps (example: calibration step 1 current = calibration step Zero)</li> <li>6 Current measured reading (example)</li> <li>7 Mean value of the measured readings recorded up to now in the current calibration step (example)</li> <li>8 Deletes the last measured reading</li> <li>9 Battery status display</li> <li>10 Number of measurements in the current calibration step (example)</li> <li>11 Continue to next calibration step / exit calibration</li> </ol> |  |
|--|--|

## 9.4.2 Calibration step *Std* – procedure

Measure on the calibration foil that is directly on top of the uncoated reference piece.

### Required material

- Base material, reference piece from customer's own production, without the coating to be measured already used during the *Zero* calibration step.
- Calibration foils with the desired thicknesses or from the scope of supply for the connected probe, the circle on the foil marks the specified measuring area

### To perform the zero calibration step *Std*

1. Place the calibration foil (1/2) (= Std. 1/2) on the uncoated reference piece.

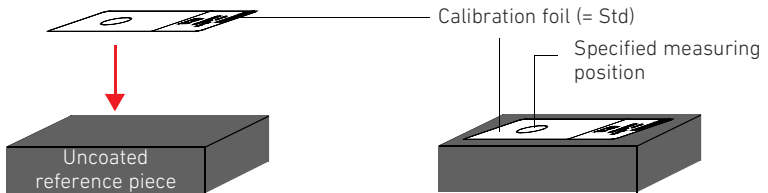

❗ Only one foil at a time may be on top of the uncoated reference piece!

2. Perform 5 to 10 measurements on the calibration foil (Std. 1).

#### A Position the gauge

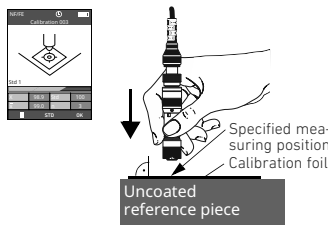

#### B Measured reading acquisition

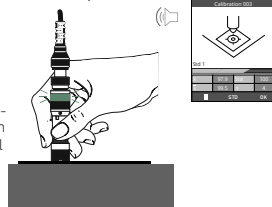

#### C Lift off the probe

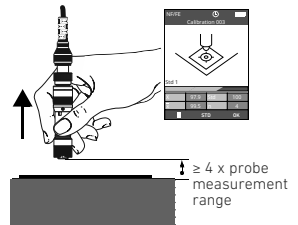

The display screens should be considered only as examples, the gauge default modes are required here for the measured reading acquisition.

🔄 Repeat Steps A to C for the subsequent measurements on the uncoated reference piece.

3. Enter the nominal value of the Std. 1: *STD* > set nominal value > *OK*.

4. Finish the calibration step Std 1: *OK*.
5. What would you like to do?
  - ▶ Finish the calibration: **1 x** ↻  
 The measuring system is now calibrated to the base material (Zero) and the part geometry as well as to a reference value (Std 1), the calibration is finished, the calibration menu with the calibration list appears in the display
  - ▶ Continue the calibration with the 2nd calibration standard: *OK* > repeat steps 1. to 4. with the second calibration foil (Std 2)  
 The measuring system is now calibrated to the base material (Zero) and the part geometry as well as to two reference values (Std 1 and Std 2), the calibration is finished, the calibration menu with the calibration list appears in the display.

## Display description – Std calibration step

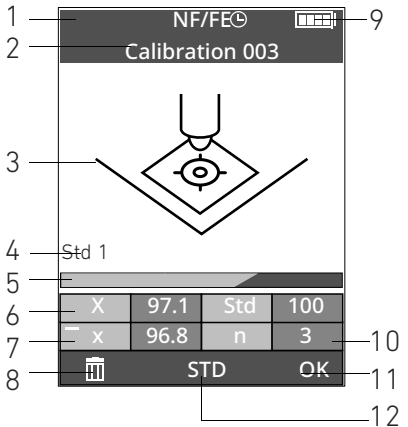
- |   |   |     |      |     |     |   |      |   |   |
|---|---|-----|------|-----|-----|---|------|---|---|
| <ol style="list-style-type: none"> <li>1 Base material currently being measured (example FE)</li> <li>2 Name of calibration (example)</li> <li>3 Schematic illustration of the current calibration step</li> <li>4 Current calibration step</li> <li>5 Progress display of the calibration steps (example: calibration step 2 current = calibration step Std 1)</li> <li>6 Current measured reading (example)</li> <li>7 Mean value of the measured readings recorded up to now in the current calibration step (example)</li> <li>8 Deletes the last measured reading</li> <li>9 Battery status display</li> <li>10 Number of measurements in the current calibration step (example)</li> <li>11 Continue to next calibration step / exit calibration</li> <li>12 Opens the page for entering the nominal value of the foil</li> </ol> |  <p>The screenshot shows a handheld device display for 'Calibration 003'. At the top, it shows 'NF/FE' and a battery icon (9). Below is the title 'Calibration 003' (2). A schematic diagram of a probe measuring a part is shown (3). Below the diagram, 'Std 1' is indicated (4). A progress bar shows the current step (5). A data table is displayed (6):</p> <table border="1" style="margin-left: 40px;"> <tr> <td>X</td> <td>97.1</td> <td>Std</td> <td>100</td> </tr> <tr> <td>x</td> <td>96.8</td> <td>n</td> <td>3</td> </tr> </table> <p>At the bottom, there is a 'STD' button with a trash icon (8) and an 'OK' button (11). A line from callout 12 points to the 'STD' button.</p> | X   | 97.1 | Std | 100 | x | 96.8 | n | 3 |
| X   | 97.1  | Std | 100  |     |     |   |      |   |   |
| x   | 96.8  | n   | 3    |     |     |   |      |   |   |



## 9.5 Calling up information about the calibration

You can call up information for a selected calibration.

### Before you start

- The probe containing the calibration whose information you want to view is connected to the gauge.
- If the calibration whose information you want to call up is locked, you need to know the lock code.

### To call up information about a calibration

1. Select the calibration whose information you want to call up:  > *Calibrations* > *OK* > select name of the calibration > *OK*.
2. Prompted to set the lock code?
  - Yes: Set the lock code: 
  - No: Continue with step 3.
3. Open the information page: *Info* > *OK*.
4. Exit the information page: .

### Description of parameters on page *Info*

Only the standards, with their values, that were used for the calibration are displayed on the information page next to the date and time.

*Std 1 (NF/FE): 100  $\mu\text{m}$  (example)*

Calibration on ferrous base material (FE), indication of the foil thickness (nominal value) for the Std. 1, used for this calibration.

*Std 2 (NF/FE): 527  $\mu\text{m}$  (example)*

Calibration on ferrous base material (FE), indication of the foil thickness (nominal value) for foil 2 used for this calibration.

*Std 1 (NC/NF): 89.9  $\mu\text{m}$  (example)*

Calibration on non-magnetizable base material (NF), indication of the foil thickness (nominal value) for foil 1 used for this calibration.

Std 2 (NC/NF): 201  $\mu\text{m}$  (example)

Calibration on non-magnetizable base material (NF), indication of the foil thickness (nominal value) for foil 2 used for this calibration.

Date / Time:

13.04.2022 10:23 (example): storage time of calibration





## 9.6 Activating/deactivating semi-automatic calibration routine



The *Shortened course* function activates a semi-automatic calibration routine for the selected calibration. If the *Shortened course* function is activated, the calibration routine switches automatically to the next calibration step after every 3 measurements. The next calibration step is signaled only through the display of the required standard value. It is not possible to correct/change the specified calibration standard when this function is activated.

### Before you start

- The probe is connected to the gauge containing the calibration for which you want to activate/deactivate the semi-automatic calibration routine.
- If the calibration for which you want to activate or deactivate this function is locked, you need to know the lock code.

### To activate/deactivate the function for a calibration

1. Select the calibration for which you want to activate/deactivate the function:  > *Calibrations* > *OK* > select name of calibration > *OK*.
2. Prompted to set the lock code?
  - Yes: Set the lock code and deactivate the lock function,  73  
function is deactivated: 
  - No: Continue with step 3.
3. Activate/deactivate the function: *Shortened course* > *OK*.  
Function is activated:   
At the next recalibration, the calibration routine will be performed semi-automatically.  
Function is deactivated: 

4. Did you deactivate the lock function in step 2.?
  - Yes: Reactivate the lock function,  72  
function is activated: 
  - No: Continue with step 5.
5. Exit the menu: , the function is now activated/deactivated.







## 9.7 Calibration - reset

You can reset a calibration and delete all the correction values (coating thickness) of the selected calibration. The function deletes all parameters measured in the *Std* calibration steps. The entered standard nominal values and the measurements of the *Zero* calibration step are retained.

### Before you start

- The probe is connected to the gauge containing the calibration you want to reset.
- If the calibration for which you want to activate or deactivate this function is locked, you need to know the lock code.

### To reset the selected calibration



1. Select the calibration you want to reset:  > *Calibrations* > *OK* > select name of calibration > *OK*.
2. Prompted to set the lock code?
  - Yes: Set the lock code and deactivate the lock function,  73.  
Function is activated: 
  - No: Continue with step 3.
3. Start the function: *Reset* > *OK*.
4. Confirm the prompt asking whether you want to proceed with the *Reset*: 
5. Did you deactivate the lock function in step 2.?
  - Yes: Reactivate the lock function,  72  
function is activated: 
  - No: Continue with step 6.
6. Exit the menu: , the calibration has now been reset.

## 9.8 Creating new calibration



In the following cases, you have to record the influencing variables with a new calibration in order to compensate for them when measuring.

- When there is a new specimen, the material properties, geometry and coating thickness range for which no calibration has yet been created.
- You have determined during test measurements that none of the listed calibrations is suitable for the specimen at hand.



### Before you start

- Refer to the notes on calibration,  56.
- The probe with which the new calibration is to be performed is connected to the gauge.
- Reference piece and/or calibration standards (calibration foils) are ready. The parts you need depends on the specifications in the directives/standards or the measurement accuracy required.  
 Overview of calibration methods, page 55

### To create a new calibration

1. Open the calibration menu *New*:  > *Calibrations* > *OK* > *New* > *OK*.
2. Follow the routine and perform the desired calibration steps (Zero, Std. 1/2).
  - a "Calibration step Zero – Procedure",  59
  - b "Calibration step Std – procedure",  61

This completes the creation process for a new calibration. The calibration is stored in the connected probe or in the DMP-F probe adapter under the probe identifier of the connected probe.

-  Keep in mind that many calibrations involving different calibration methods for different base materials can be stored in the probe/DMP-F probe adapter. A unique name makes it easier to select and assign the desired calibration to a batch.  
 Calibration - assigning/changing names, page 67

## 9.9 Calibration - assigning/changing names







Assign a unique name to the calibration (calibration method, material designation, batch no., ...), example: Z+1F EN AW 6082 or Z EN AW 6082.



-  Keep in mind that many calibrations involving different calibration methods for different base materials can be stored in the probe/DMP-F probe adapter. A unique name makes it easier to select and assign the desired calibration to a batch.

### Before you start

- The probe is connected to the gauge (via DMP-F probe adapter) containing the calibration whose name you want to change.
- If the calibration whose name you want to change is locked, you need to know the lock code.

### To change the name of a calibration

1. Select the calibration whose name you want to change:  > *Calibrations* > *OK* > select name of calibration > *OK*.
2. Prompted to set the lock code?
  - Yes: Set the lock code and deactivate the lock function,  73.  
Function is deactivated: 
  - No: Continue with step 3.
3. Open the input menu: *Rename* > *OK*.
4. Change the name:
  - Move cursor using the  and *OK* keys
  - Select characters using the  and *OK* keys
  - Delete characters by selecting the space 
5. Exit the input menu:
  - a Move the cursor to the far right using the *OK* key. The character  appears at the right edge of the display.
  - b Press *OK* to close the input menu.

6. Did you deactivate the lock function in step 2?
  - Yes: Reactivate the lock function:  72.  
Function is activated: 
  - No: Continue with step 7.
7. Exit the calibration menu: , the name has now been changed.

## 9.10 Checking the precision of a calibration



The *Check Calibration* function checks during a control measurement whether the mean value of the control measurement matches the nominal value of the used foil within the measurement uncertainty (in accordance with ISO/IEC Guide 98-3).

### Important to know



- The *Check Calibration* function allows you to check the calibration state of the selected calibration and the measurement accuracy of the measurement system. The result of the check applies only to the calibration selected.
- The check must be performed under the same conditions applied for the calibration procedure, at the same temperature, using the same base material for example.
- The precision of the calibration is limited by the measurement uncertainty of the calibration standard (calibration foil). The measurement uncertainty of the calibration must not be smaller than the measurement uncertainty of the calibration standard used. To improve the calibration precision, you must use calibration standards with smaller measurement uncertainties for the calibration procedure.
- The determined measurement uncertainty applies only to a small range around the nominal value of the foil for which the control measurement was performed.

If you wish to determine the measurement uncertainty for a measurement range, perform control measurements on two foils that limit the measurement range. You can determine the measurement uncertainty for this measurement range through a linear interpolation of the two measurement uncertainties of the control measurements on the two foils.

## Before you start

- The test parameters for the selected calibration are defined. Defining the test settings,  71.
- The probe is connected to the gauge containing the calibration you want to check.
- Reference piece and a calibration standard (calibration foil) already used for the calibration procedure are ready. You can find the parts you need on the calibration info page:  > *Calibrations* > *OK* > select name of calibration > *OK* > *Info*.
- Before the control measurement is carried out, the gauge with connected probe must have been switched on for at least 10 minutes! This is necessary to ensure that all gauge components have reached their operating temperature. Otherwise, slightly increased measurement errors can occur!
- If the calibration you want to check is locked, you need to know the lock code.

## To check the desired calibration

1. Select the calibration whose measurement accuracy you want to check:  > *Calibrations* > *OK* > select name of calibration > *OK*.
2. Prompted to set the lock code?
  - Yes: Set the lock code and deactivate the lock function,  73.  
Function is deactivated: 
  - No: Continue with step 3.
3. Start the function: *Check Calibration* > *OK*.
4. Place the foil for the control measurement on the base material.
5. Take a few control measurements on the foil. We recommend taking 10 measurements. The circle on the foil marks the specified measurement area.  
Description of the displayed variables on the *Check Calibration* page:
  - *Val.*: Nominal value of the calibration standard (calibration foil), set in the *Def. Cal. Check* menu.
  - $\Delta abs$ : Tolerance/uncertainty of the foil, set in the *Def. Cal. Check* menu.
  - *Nmin*: Minimum number of required measurements
  - $\bar{x}$ : Arithmetic mean value, determined from the measurements taken; red values are outside the tolerance limits

- $s$ : Standard deviation, determined from the measurements taken; red values are outside the tolerance limits
- $n$ : Number of measurements taken

6. Start the check: *OK*

7. An information page displays the following result:

*Calibration is OK*

The mean value of the control measurement matches the nominal value (= reference value) of the used calibration standard (calibration foil) within the measurement uncertainty (in accordance with ISO/IEC Guide 98-3). This means that the difference between the mean value and the nominal value cannot be distinguished from the specified measurement uncertainty of the calibration standard. The measurement accuracy for the open batch is OK for the calibration standard used and cannot be further improved by this calibration standard.

*Calibration is NOT OK*

The measured mean value of the control measurement has an excessive deviation from the nominal value of the calibration standard (calibration foil). First, perform a recalibration. Be sure to use standard values appropriate for the selected calibration method.



- The data sheet of the probe provides the values available and suitable for the calibration standard(s).
- Also refer to the note on "Precision" on page 68.

8. Finish the check: *OK*

9. Did you deactivate the lock function in step 2.?

- Yes: Reactivate the lock function, 72.  
Function is activated:
- No: Continue with step 10.

10. Exit the calibration menu: , the calibration check has finished.



Tips

- If the calibration check fails even after recalibration, perform a new recalibration only with calibration step *Zero*, skipping the other calibration steps via .
- Reset the calibration using the *Reset* function, 65



## 9.11 Defining the test criteria for the calibration check

You can perform a control measurement to check the precision of a selected calibration. The check is based on the measurement uncertainty (tolerance) specified for the calibration standard (calibration foil) used during the control measurement. To be able to check a calibration, you have to enter for this calibration the measurement uncertainty or tolerance for the calibration standard you want to use for the check (control measurement).

### Before you start

- You know the tolerance or the measurement uncertainty ( $k=2$ ) for the calibration standard to be used later during the control measurement. These values can be noted in a certificate or on the calibration standard itself.
- The probe is connected to the gauge containing the calibration whose test criteria you want to define.
- Please also refer to section "Important to know",  68.
- If the calibration whose test parameters you want to enter for the check is locked, you need to know the lock code.

### To define the test criteria



1. Select the calibration for which you want to enter the test criteria:  > *Calibrations* > *OK* > select name of calibration > *OK*.
2. Prompted to set the lock code?
  - Yes: Set the lock code and deactivate the lock function,  73.  
Function is deactivated:
  - No: Continue with step 3.
3. Open the settings menu: *Define Cal. Check* > *OK*.
4. Select the format in which you have the uncertainty/tolerance values for the calibration standard you intend to use for the check (control measurement) later: select desired tolerance value > *OK*.  
Parameter is activated:   
Parameter selection:
  - *No*: Check function deactivated
  - *Abs. Tol.*, example:  $\pm 1.5 \mu\text{m}$

- *Rel. Tol.*, percentage value, example:  $\pm 1.25 \%$
  - *Uncertainty*, example: expanded measurement uncertainty for an expansion factor  $k=2$ :  $\pm 4.5 \mu\text{m}$
5. Set the nominal value and the tolerance/measurement uncertainty for the calibration standard you intend to use for the check (control measurement) later: *Reference Value* > *OK* > set value > *OK*.

Repeat Step 5. for the tolerance/uncertainty.

-  When entering, pay attention to the unit of measurement. Enter the values in the unit of measurement set for the currently open batch.

Input parameters:

- *Reference Value*: Nominal value of the calibration standard
  - *Abs. Tol./Rel. Tol. or U(k=2)*: Tolerance/measurement uncertainty value of the calibration standard
6. Did you deactivate the lock function in step 2.?
- Yes: Reactivate the lock function,  72.  
Function is activated: 
  - No: Continue with step 7.
7. Exit the menu: , the test criteria are now defined.

## 9.12 Lock calibration

The *Lock Calibration* function locks the opening and the calibration routine of the selected calibration. You can unlock the menu for the locked calibration and calibration routine only by entering the lock code. This lock function can be used only if a lock code is defined in the gauge.

Before you start

- The probe is connected to the gauge containing the calibration you want to lock.
- A lock code is defined in the gauge,  94

To lock a calibration

1. Select the calibration you want to lock:  > *Calibrations* > *OK* > select name of calibration > *OK*.

2. Activate the lock function: *Lock Calibration* > *OK*.

Function is activated: 

3. Exit the menu: , the locking process has finished.

To access the menu and the calibration routine of the locked calibration, you now need to enter the lock code.



## 9.13 Calibration – deactivating lock

The *Lock Calibration* function blocks access to the menu and to the calibration routine of the selected calibration. You can deactivate the lock function for the menu and the calibration routine of the locked calibration only by entering the lock code.



### Before you start

- The probe is connected to the gauge containing the calibration whose lock you want to deactivate.
- To deactivate the lock function of a calibration, you need to know the lock code.

### To deactivate the lock of selected calibration

1. Select the calibration whose lock you want to deactivate:  > *Calibrations* > *OK*  
> select name of calibration > *OK*.
2. Deactivate the lock:
  - a Set the lock code: set lock code > *OK*.
  - b Deactivate the lock function: *Lock Calibration* > *OK*.  
Function is deactivated: 

The unlocking process is finished, you now have free access to the functions in the menu of the selected calibration.

-  Before exiting the calibration, do not forget to reactivate the lock function for the menu of the selected calibration,  72.





## 9.14 Deleting a calibration

You can delete individual calibrations from the memory of the probe/DMP-F probe adapter.

### Before you start

- The probe is connected to the gauge containing the memory from which you want to delete a calibration.
- If the calibration you want to delete is locked, you need to know the lock code.

### To delete a calibration

1. Select the calibration you want to delete:  > *Calibrations* > *OK* > select name of calibration > *OK*.
2. Prompted to set the lock code?
  - Yes: Set the lock code and deactivate the lock function,  73.  
Function is deactivated:
  - No: Continue with step 3.
3. Select the delete function: *Delete* > *OK*.
4. Start the delete process: .
5. Exit the menu: , the delete process has finished.

## 9.15 Deleting all calibrations

You can delete all your calibrations from the memory of the connected probe. This function deletes all the calibration files and all their data!

DMP-F probe adapter: You can use this function to delete all calibrations from the DMP-F probe adapter that were created using the connected probe. Useful when an existing probe is to be replaced by a new one. In this case, the calibrations of the old (e.g. defective) probe are no longer needed, so they can be deleted and do not unnecessarily take up memory space in the DMP-F probe adapter.



### ATTENTION

- Please note that a measurement without a calibration is not possible!
- You must assign a new calibration to each batch already created!
- Using this function you also delete the locked calibrations in the probe/DMP-F probe adapter!

## Before you start

- The probe is connected to the gauge containing the memory from which you want to delete all calibrations.

## To delete all calibrations from the memory of the connected probe

1. Call up the delete function:  > *Gauge Settings* > *OK* > *Probe - Menu* > *OK* > *Delete all calibrations* > *OK*.
2. Start the delete process: .
3. Exit the menu: , the delete process has finished.

The delete process has finished, the calibration memory of the probe is now empty.



### **What you should do next**



- Create new calibration(s), see page 66
- Assign the new calibrations to the batches, page 44

## 10 Evaluation

The gauge provides you with the mathematical calculations, complex and extensive at times, needed for statistical evaluation of the measured readings from the opened batch and the measurement blocks when automatic block formation is switched on. The evaluation refreshes continuously in the background during the measurement.

The statistical characteristic variables of the open batch are displayed in the *Statistics* menu. If automatic block formation is activated for the open batch, you can also display the statistical evaluation for each measured reading block. Either the individual measurements or the block average values are considered and displayed as measured readings in the statistical evaluation.

### 10.1 Batch statistics

- Display statistical characteristic variables for all measured readings of the open batch:  > *Statistics* > *OK*.
- Display histogram for all measured readings of the open batch (possible from 5 measured readings):  > *Statistics* > *OK* >  > *Batch Charts* > *OK* > *Histogram* > *OK*.

If no measurement data appear for the class division, the display refers to the entire measurement range of the connected probe.



Description of the characteristic variables, see page 15

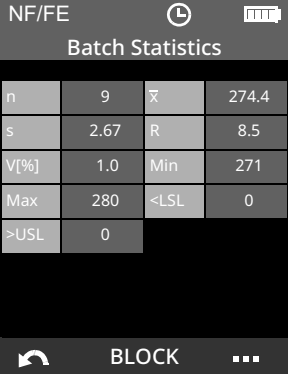

Batch Statistics			
n	9	$\bar{x}$	274.4
s	2.67	R	8.5
V[%]	1.0	Min	271
Max	280	<LSL	0
>USL	0		

Example of batch statistics

## 10.2 Block statistics

- Display statistical characteristic variables for each measured reading block: ☰ > *Statistics* > *OK* > *BLOCK*.

⬆️: Scroll through the individual block statistics (block no. 1 to x)



Description of the characteristic variables, see page 15

## 10.3 Individual measured readings

- Display the individual measured readings of the selected measured reading block: ☰ > *Statistics* > *OK* > *BLOCK* > ●●● > *Block Readings* > *OK*.

⬆️: Scroll through the individual measured readings of the selected measured reading block (possible from block size > 6).

NF/FE			
Block Statistics			
No.	4	$\bar{x}$	127.7
n	3	s	2.45
R	4.5	V[%]	1.9
Min	125	Max	129
<LSL	0	>USL	0

*Example: Block statistics of measured reading block number 4*

## 11 Data transfer

Data export is possible only from the gauge to the Tactile Suite software program. Individual measured readings, batch statistics, block statistics and the entire batch can be exported to Tactile Suite.

Tactile Suite is a software solution for evaluating measured readings, creating inspection reports, archiving measured readings, inspection reports and batch files, and for exporting measured readings in CSV format.

You can download the Tactile Suite program free of charge from the Fischer download page.

Information on how to use the Tactile Suite software program can be found in the corresponding Operator's Manual ( Tactile Suite).

Fischer download page: <https://docs.helmut-fischer.com/uum>



### Notes on data transfer

- Calibration data cannot be transferred.
- Interfaces: USB and Fischer-Bluetooth® stick
- You can write the measured readings directly into an Excel spreadsheet online via Tactile Suite during the measurement.

## 11.1 Data transfer via USB

### Before you start

- The Tactile Suite software program is installed on the PC and opened.
- The gauge is switched off.
- The USB cable from the scope of supply is ready.

For the data transfer, use the USB cable from the scope of supply or any other commercially available USB cable with a C/A-type plug; maximum usable cable length: 3 m (118.1 ")

### To transfer data to Tactile Suite via USB

1. Connect the gauge to your PC.  
Use the USB connection on the top of the gauge.

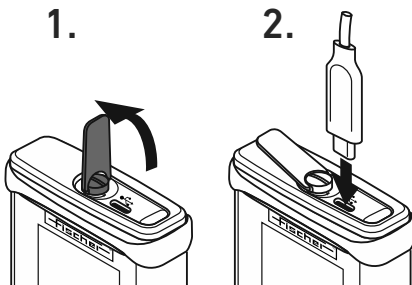



2. Switch on the gauge: 

The gauge is automatically detected and displayed in Tactile Suite in the menu on the left. All data from the gauge are synchronized with Tactile Suite.

## 11.2 Data transfer via Bluetooth

To transfer data using Bluetooth®, you need the special Fischer-Bluetooth stick, included in the scope of supply.

Before you start

- The Tactile Suite software program is installed on the PC.
- The Fischer-Bluetooth stick from the scope of supply is ready.
- The battery in the gauge is charged,  31.
- The automatic gauge shutdown function is deactivated,  92.





ATTENTION – interruption to data transfer

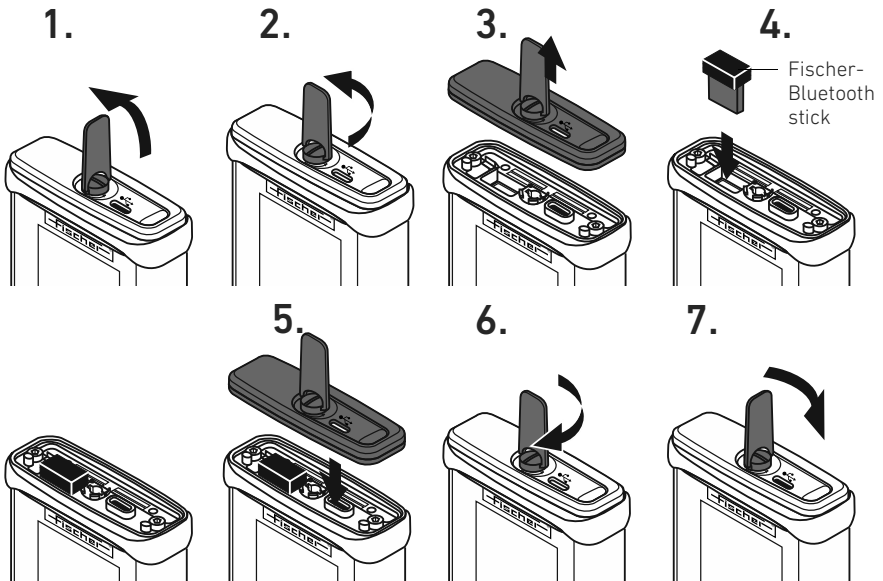

Please note that switching off the gauge interrupts data transfer!

To transfer data to Tactile Suite via Bluetooth

1. Insert the Fischer-Bluetooth stick into the gauge:



2. Switch on the gauge: 

3. Activate the Fischer-Bluetooth stick:  > *Gauge Settings* > *OK* > *Bluetooth* > *OK*.  
function is activated:   
A white Bluetooth icon appears in the uppermost header to indicate that the Fischer-Bluetooth stick is activated.
4. Exit the menu: , the settings in the gauge are now made.
5. PC: Establish the Bluetooth connection to your PC. Add the gauge (Helmut Fischer GmbH BT Device) as a new gauge or refresh the connection.  
Gauge: A blue Bluetooth icon appears in the uppermost header to indicate that a Bluetooth connection has been established.
6. PC: Open Tactile Suite on your PC.  
The gauge is automatically detected and displayed in Tactile Suite in the menu on the left. All data from the gauge are synchronized with Tactile Suite.

The connection settings are now made.

## 12 Batch settings

For the open batch, you can make settings that do not directly affect the measurement, such as changing the Measurement view, the max. number of decimal places for the displayed values or calling up the batch information.



### 12.1 Calling up information about the open batch

You can call up information about the open batch. All settings, assigned calibration and probe information used to create this batch are listed on an information page.

Before you start

- The batch for which you want to view the information is open in the gauge.

To call up information about the open batch

1.  > *Batch Modify* > *OK* > *Batch Info* > *OK*
2. Exit the information page: 

Description of parameters on page *Batch Info*

*Batch Name*

Name of the batch file.

*Probe Name*

Name of the probe used to create this batch.

*Probe Serial Number*

Serial number of the probe used to create this batch.

*Calibration*

Name of the calibration assigned to this batch.

*Limits [ $\mu\text{m}$ ]*

Information on specification limit monitoring: off or indication of the specification limits (LSL and USL)/ the specification limit (LSL).

### *Measurement View*

Type of Measurement view set for this batch (Simple, Statistics).

### *Meas. unit*

$\mu\text{m}$  (example)

### *Block Size*

Number of measured readings collected in a block.

### *Offset*

Information about the offset: off or set offset value.

### *Measure Mode*

Information about the set measuring mode: *Single Readings*, *Free Running* or *Scan* with the set scan parameters

### *Values rounding*

Information about the resolution of the displayed values: number of decimal places used to display the measured reading and the statistical values.

### *Save Readings*

Information indicating whether this function is activated or deactivated for this batch.

### *Air Reference*

Information indicating how the probe acquires the air value for this batch.

## **12.2 Changing the unit of measurement for the batch**



You can change the unit of measurement for the open batch, as well as its block and batch statistics.

block and Before you start



- The batch for which you want to make the changes is open in the gauge.

To change the unit of measurement

1.  > *Batch Modify* > *OK* > *Meas. unit* > *OK* > select desired unit of measurement > *OK*  
Unit of measurement is activated:
2. Have you selected the *Own Unit* unit of measurement?
  - No: Continue with step 3.

- Yes: Set the desired variables for your own unit of measurement:
  - a  : Select the parameter *Own Multiplier* and set the multiplier related to the unit of measurement  $\mu\text{m}$ .
  - b  : Select the parameter *Own Unit* and assign a name for the unit of measurement.

Change the name:

- Move cursor using the  and *OK* keys
- Select characters using the  and *OK* keys
- Delete characters by selecting the space ()

Exit the dialog page *Rename*:

- a Use the *OK* key to move the cursor to the far right until the character  appears at the right edge of the display.
- b Exit the dialog page: *OK*.

3. Exit the menu: , the settings are now made.

The previous measured readings and statistical evaluations are converted and displayed according to the newly set unit of measurement.

## 12.3 Selecting the Measurement view for the batch

You can display various items of additional information for the open batch. You can choose between two Measurement views.

*The display screens below should be considered only as examples; batch 001 has set specification limits.*

Measurement view  
*Simple*

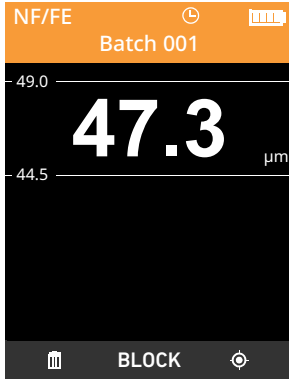

*Only the current measured reading is displayed.*

Measurement view  
*Statistics (default mode)*



*In addition to the current measured reading, a measured reading statistic is shown in a table.*

Before you start

- The batch for which you want to make the changes is open in the gauge.

To select a Measurement view

1. > *Batch Modify* > *OK* > *Views Settings* > *OK* > *Measurement View* > *OK* > select desired Measurement view > *OK*  
Measurement view is activated:

2. Have you selected the *Statistics* Measurement view?

- Yes: Select the desired characteristic variables:

a  > OK.

Characteristic variable is switched on: 

A maximum of 6 characteristic variables can be displayed in the Measurement view *Statistics*, description of characteristic variables,  15.

b Continue with step 3.

- No: Continue with step 3.

3. Exit the menu: , the settings are now made.

The measured readings (and statistical evaluations) are displayed according to the newly set Measurement view.

## 12.4 Selecting characteristic variables for the statistical displays

For the open batch, you can select the statistical characteristic variables that are to be displayed on the evaluation pages *Batch Statistics* and *Block Statistics*.

Before you start

- The batch for which you want to make the changes is open in the gauge.

To select the statistical characteristic variables

1.  > *Batch Modify* > OK > *Views Settings* > OK > *Batch Statistics View* or *Block Statistics View* > OK

2. Select the desired characteristic variables:  > OK.

Characteristic variable is activated: 

Description of the characteristic variables,  15

3. Exit the menu: , the settings are now made.

## 12.5 Setting the decimal places for the display values

For the open batch, you can set the number of decimal places for displaying the measured reading and for the values of the statistical characteristic variables both in the Measurement view and in the statistical displays.

Before you start

- The batch for which you want to make the changes is open in the gauge.

To set the decimal places for the display values

1.  > *Batch Modify* > *OK* > *More Settings* > *OK* > *Values rounding* > *OK* > select desired max. number of decimal places > *OK*

Parameter is selected:

Parameter selection:

- *Low*: maximum 1 decimal place is displayed  
0.9 / 9.9 / 99 / 999 / 9999
- *Medium*: maximum 2 decimal places are displayed  
0.99 / 9.9 / 99.9 / 999 / 9999
- *High*: maximum 3 decimal places are displayed  
0.999 / 9.99 / 99.99 / 999.9 / 9999
- *Navsea*:  
measured readings up to 254  $\mu\text{m}$  (10 mils) are displayed with 1 decimal place, 0.9 / 9.9 / 99.9 / 253.9  
Measured readings from 254  $\mu\text{m}$  (10 mils) are displayed as an integer, 254 / 999 / 9999

2. Exit the menu: , the settings are now made.

## 13 Batch management





You can rename, copy and delete batch files.

### 13.1 Assigning/changing batch names

You can rename every batch.

-  Keep in mind that many batch files are stored in the gauge. A unique name makes the selection process easier.

To change the name of a batch

1. Call up the Rename function:  > *Batches* > *OK* > select desired batch > *OK* > *Rename* > *OK*.
2. Change the name:
  - Move cursor using the  and *OK* keys
  - Select characters using the  and *OK* keys
  - Delete characters by selecting the space ()
3. Exit the dialog page *Rename*:
  - a Use the *OK* key to move the cursor to the far right until the character  appears at the right edge of the display.
  - b Exit the dialog page: *OK*.

The batch name has now been renamed.

### 13.2 Copying a batch



-  You can find all the information you need to copy a batch in section "Creating a new batch by copying", page 38.

### 13.3 Deleting a batch

You can delete individual batch files. The selected batch is deleted together with the measured readings.

 The opened batch cannot be deleted.

To delete a batch

1.  > *Batches* > *OK* > select desired batch > *OK* > *Batches* > *OK*
2. Start the delete process: .
3. Exit the menu: , the delete process has finished.

## 14 Gauge settings



The display language, date, and time, for example, are general gauge settings and apply to all batches.

In addition to the general gauge settings, you can also retrieve information about the gauge software, copyright, etc. from the *Gauge Settings* menu.

### 14.1 Setting the language

You can set the display language for the gauge.



To select the language

1.  > *Gauge Settings* > *OK* > *Language* > *OK* > select desired language > *OK*  
Parameter is activated:
2. Exit the menu: , the language has now been set.

### 14.2 Display settings

You can activate and deactivate the automatic flip display view according to the gauge position, and also adjust the display brightness.





To change the display settings

1.  > *Gauge Settings* > *OK* > *Display Settings* > *OK*
  - Activate/deactivate flip function for the display: *Flip Display* > *OK*.  
Parameter is activated:
  - Set display brightness: *Brightness* > *OK* > set desired brightness value > *OK*
2. Exit the menu: , the settings are now made.

### 14.3 Signal settings – visual and audible signals

You can activate and deactivate the sound and light signals, as well as the gauge vibration function for measured reading acquisition and specification limit violations.

To activate/deactivate the signals

1.  > *Gauge Settings* > *OK* > *Signal Settings* > *OK*
2. Select the desired signal function:  > *OK*.  
Function is activated: 
  - Parameter *Light intensity*, set the desired brightness value:  > *OK*  
The higher the set value, the higher the luminosity.
3. Repeat step 2. for more menu functions.
4. Exit the menu: , the settings are now made.

### Signals



The sound and light signals listed in the table are output in succession, if necessary, e.g. at the last measured reading of a block (block closure): 1 short beep followed by a long beep and the light band lights up in green, then in yellow.

Beeps/ beep	Visual signal probe + gauge	Meaning
1 x short	1 x green	Measured reading acquisition, measured reading is within the specification limits/above the specification limit when specification limit monitoring is activated
1 x short + 1 x long	2 x red	Measured reading is outside the specification limits/below the specification limit when specification limit monitoring is activated
1 x long	1 x yellow	Block closure, when automatic block formation is activated

## 14.4 Energy saving

To prolong the battery life as far as possible, the gauge offers automatic shutdown and display dimming as energy-saving functions.

To change the shutdown and dimming times, and also the dimming strength

1.  > *Gauge Settings* > *OK* > *Energy Savings* > *OK*
2. Select the desired function:  > *OK*.
3. Set the desired time value/dimming strength:  > *OK*

Shutdown time 0 min: Function deactivated, there is no automatic gauge switch-off or display dimming

max. shutdown time: 1000 min.

4. Repeat steps 2. and 3. for more menu settings.
5. Exit the menu: , the settings are now made.

### Description of the energy-saving functions

- *Switch off after*  
Automatic gauge shutdown after a preset period of time without any action (key confirmation or measured reading acquisition)
- *Switch off (USB)*  
Automatic gauge shutdown after a preset period of time without any data transfer via USB interface
- *Dim display after*  
The display brightness is automatically dimmed to the specified brightness value (*Dimming Ratio*) after a preset period of time.

## 14.5 Activating/deactivating the Bluetooth function

To transfer data using Bluetooth®, you need a special Fischer Bluetooth stick. This is included in the gauge's scope of supply. To activate Bluetooth, the function must be activated in the gauge.



Further information on establishing a Bluetooth connection and transferring data can be found on page 80.

## To activate/deactivate the Bluetooth function

1. > *Gauge Settings* > *OK* > *Bluetooth* > *OK*
2. Activate the Bluetooth function: *OK*.  
Function is enabled:
- A white Bluetooth icon in the uppermost header indicates that the Bluetooth function is activated. For a description of more icon colors, see 10.
3. Exit the menu: , the setting has now been made.

## 14.6 Date & time

You can set the date and time as well as the date and time format for the gauge.



### To set the date & time

1. > *Gauge Settings* > *OK* > *Date & Time* > *OK*
2. Select the desired parameter: > *OK*.
3. Set the desired time or date or select the desired format:  
Date and time setting
  - Move cursor using the *OK* and keys
  - Number selection using the keysFormat selection: > *OK*  
Format is selected:
4. Repeat steps 2. and 3. for more menu settings.
5. Exit the menu: , the settings are now made.



## 14.7 Default settings for unit of measurement and decimal places

You set defaults in the gauge for the unit of measurement and the maximum number of decimal places. All newly created batches are automatically assigned these default variables (*Preset Unit* and *Preset rounding*).

To change the unit of measurement

1.  > *Gauge Settings* > *OK* > *More Settings* > *Preset Unit* > *OK* > select desired unit of measurement > *OK*  
Unit of measurement is activated:
2. Exit the menu: , the settings are now made.



To set the number of decimal places for the display values

1.  > *Gauge Settings* > *OK* > *More Settings* > *OK* > *Preset rounding* > *OK* > select desired max. number of decimal places > *OK*  
Parameter is selected:   
Parameter selection:
  - *Low*: maximum 1 decimal place is displayed 0.9 / 9.9 / 99 / 999 / 9999
  - *Medium*: maximum 2 decimal places are displayed 0.99 / 9.9 / 99.9 / 999 / 9999
  - *High*: maximum 3 decimal places are displayed 0.999 / 9.99 / 99.99 / 999.9 / 9999
  - *Navsea*: measured readings up to 254  $\mu\text{m}$  (10 mils) are displayed with 1 decimal place, 0.9 / 9.9 / 99.9 / 253.9
2. Exit the menu: , the settings are now made.

## 14.8 Activating/deactivating lock code



Use the lock code to activate/deactivate the lock function (*Lock Calibration*) for selected calibrations.

## To activate the lock code

1.  > *Gauge Settings* > *OK* > *More Settings* > *Define Lock Code* > *OK* > set desired lock code > *OK*
2. Confirm the activation information: *OK*
3. Exit the menu: , the lock code has now been activated.

## To deactivate the lock code

 You must know the lock code to deactivate it.



1.  > *Gauge Settings* > *OK* > *More Settings* > *Delete Lock Code* > *OK* > set lock code > *OK*
2. Confirm the deactivation information: *OK*
3. Exit the menu: , the lock code has now been deactivated.

## 14.9 Reducing electromagnetic interference on the measurement

When the magnetic induction test method is used, the electromagnetic interference radiation from the local mains voltage can influence the coating thickness measurement. Such interference radiation can occur close to transformers, for example. When the local mains frequency is selected, the gauge compensates for this interference.

Not relevant for the ISOSCOPE® gauge models

## To set the frequency of the local voltage supply

1.  > *Gauge Settings* > *OK* > *Probe - Menu* > *OK* > *Set Power Line Frequency* > *OK* > select local mains frequency > *OK*  
Parameter is selected: 
2. Exit the menu: , the settings are now made.

### 15.1 Probe – count rate recording/display

For error analysis, it can be helpful to view the count rates delivered directly from the probe. Our experts can use the count rates shown in the display to draw conclusions about the status of the probe, for example, and propose potential solutions.

The count rates are measured and displayed in a service area, and this does not affect the batches created in the gauge.

You can also export the count rates, although only during the measurement (online), to an Excel® table via USB and Tactile Suite.

#### Before you start

- The probe with count rates to be checked is connected to the gauge.
- For a data transfer to Excel®, the software programs Tactile Suite and MS Excel are installed on the PC and opened. The USB cable from the scope of supply is ready.

For the data transfer, use the USB cable from the scope of supply or any other commercially available USB cable with a C/A-type plug; maximum usable cable length: 3 m (118.1 ")

 The link for downloading Tactile Suite and additional information can be found on page 78.

#### To display/export the count rates

1.  > *Gauge Settings* > *OK* > *Probe - Menu* > *OK* > *Probe Raw Values* > *OK* > *Count rate - Check* > *OK*
2. Carry out one of the following measuring methods:
  - Individual measurements
  - Continuous count rate recording:  
Place the gauge on the surface and press *RUN*; the gauge displays the continuously recorded count rates.

Finish continuous count rate recording: *STOP*

*TH*

Switches to coating thickness display in the count rate Measurement view (unit of measurement set as in the open batch)

*XN*

Switches to count rate display in the count rate Measurement display

3. Exit the menu: , the settings are now made.

## 15.2 Gauge cleaning

-  Switch off the gauge before cleaning it!

### Cleaning the gauge

- ▶ Simply wipe away normal soiling, such as dust, with a damp cloth.
- ▶ Wipe away oily deposits with a dry cloth and then clean the spots with plastic cleaner or household detergent.
- ▶ Remove paint and lacquer using a solvent. Use solvents such as acetone, methyl ethyl ketone, turpentine oil, or xylene to clean the gauge.



#### **ATTENTION** – Damage to the gauge/probe

- Do not clean the gauge/probe under running water!
- IP64 ≠ water-proof, gauges in protection class IP64 are resistant only to splash water. They are not waterproof and cannot withstand constant water pressure!
- Scratches on the display  
Cleaning the display with a dry cloth can scratch the display.

## 16 Gauge information

All gauge information, such as information about its status, firmware and legal information can be found in the *Gauge Settings* menu.

To call up the information page

1.  > *Gauge Settings* > *OK* > *About* > *OK*  
     : Scroll, display next page
2. Exit the information page: 







[www.helmut-fischer.com](http://www.helmut-fischer.com)

**fischer**®